

VACOMASS[®]

Technical Information

VACOMASS[®] jet control valve



THE VACOMASS® jet control valve

The **VACOMASS® jet control valve** is an innovative, flow-optimized stainless steel control valve that closes gas-tight and offers a linear operating characteristic over virtually the entire operating range. The valve has been developed and optimized specifically for high precision air control and distribution with minimal pressure loss, resulting in comparatively low operating costs.

In terms of control range and product quality, this development represents a milestone in the evolution of air control valves and fittings. It is unique and with worldwide patent applications.

Other features include:

- A central control axis with actuator for sensitive control of air supply with 360° free-flow annular orifice – allows the installation of the air flow meter ½ D directly in front of the control valve
- Stroke adjustment takes place in the direction of flow: this means the flow remains attached to the wall, thereby facilitating rapid and effective pressure recovery with extremely low pressure loss – saves energy costs
- In most cases the valve can be fitted directly in the pipe without pipe reduction/expansion – saves installation costs
- The flow in the Venturi outlet is homogeneous, so that the first drop leg to a diffuser grid can be located directly behind the valve – improves the process
- The required (measurement and) control section is comparatively short – the ideal prerequisite for retrofitting in existing installations
- The control element has a very low coefficient of drag and therefore requires only low drive torque; low friction operation allows for compact actuator sizes – reduced investment and operating costs
- Corrosion-proof high grade stainless steel control valve designed for ambient and gas temperatures from -40 °C to +150 °C, lubricant-free in exposed areas – reduced operating and maintenance costs
- Gas-tight closure, making it suitable for swing zone operation and process optimization, making an additional automated shut-off valve and its associated costs unnecessary
- A virtually linear operating characteristic and control precision of better than 0.2%, constant control accuracy and virtually constant low coefficient of drag over the entire control range – these are optimum prerequisites for precise and stable control in conjunction with an ideal gain factor of around 1
- Comes with the **VACOMASS® actuator**, direct flange mounting with low drive torque – the innovative control valve is designed to operate with very low actuating forces; in addition to AUMA and ROTORK other makes are possible provided they meet the technical specifications

LAYOUT OF THE CONTROL PIPE SECTION

The **VACOMASS® jet control valve** performs the following tasks in aeration tanks: 1. controlling the flow of oxygen into a tank based on actual demand and 2. distributing aeration air to individual tanks or aeration zones as required in interconnected systems.

In the past, a conventional oxygen control loop was set up and the valve opened and closed based on the difference between the DO setpoint and actual DO value. This arrangement resulted in a distinct lag in the control system. The control system becomes notably faster when the air flow rate to a control zone is measured directly and integrated in the control concept. In the cascade control loop, the air flow rate is then the control variable for the oxygen concentration and is set with dedicated control circuits (speed control at blower, valve position). In this type of closed-loop control, the process, in the case of disturbances such as wet weather events or load fluctuations, is faster so that the treatment levels remain constant under the specified technical conditions (refer to new Guideline ATV-DVWK-M264: Gas Flow Measurement in Sewage Treatment Plants, May 2015).

Various configurations of the control system are possible depending on local conditions and the existing geometry of the piping system. When using diaphragm control valves or butterfly valves, the pipe cross section is typically reduced at the start of the measurement and control section and expanded again at the end in order to achieve the required control effect. These control elements generally exhibit a limited range of linear operation in the upper and lower stroke range. In control applications, this inevitably leads to unfavourable operation of the valve at low stroke and thus to high pressure losses and reduced control quality. Possible causes include:

- The range of air flow rates required due to daily load fluctuations
- Difficulties in achieving correct dimensioning of slide valves or butterfly valves
- Changes in air demand over time

In most cases, the **VACOMASS® jet control valve** can be installed directly in the pipe without the need to reduce/expand the diameter. Thanks to the linear operating characteristic over virtually the entire operating range, fluctuating air requirements, dimensioning errors or later changes scarcely have an impact on the performance of the valve.

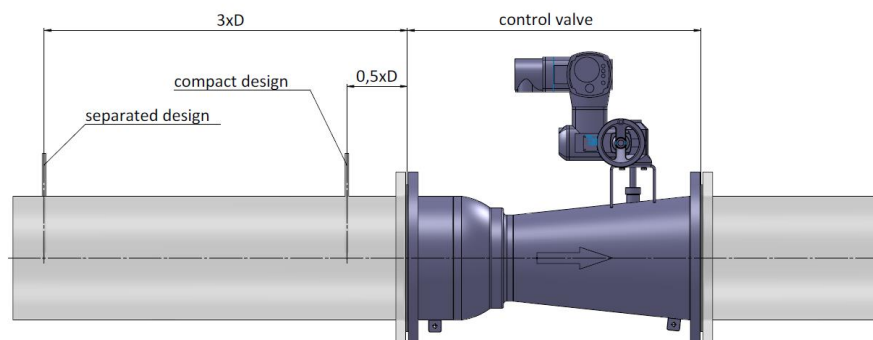

Depending on piping geometry, two types of installation can be realized:

Separated system: If there is sufficient inlet and outlet straight piping length available, the single flowmeter can be positioned at least $3 \cdot D$ in front of the jet control valve, with no influence of the stroke of the valve on the flow signal.

Compact System (Standard): The air flow meter is positioned $0.5 \cdot D$ in front of the jet control valve. As an option, three sensors can be used for redundancy. Depending on the piping in front of the flow meter and on the requirements for absolute accuracy of the flow measurement, an automatic flow profile correction of the signal(s) as a function of the jet valve stroke is a possibility.

DESIGN DETAILS

Materials: The housing and all exposed parts are made of stainless steel (V4A/316). Viton, Teflon graphite and PEEK materials are also used. All seals are static O-rings.

Maintenance: The control valve is completely maintenance-free, only the actuator requires routine maintenance as specified by the manufacturer.

Connections and installation: The control valve features a loose flange (also as ANSI flange) on both ends and, thanks to its low weight, is easy and quick to install on-site. Other fittings for diameter reduction/expansion are generally not required.

The **VACOMASS® flow meter** can be installed with a very short inlet section directly ahead of the control valve.

Option:

The control valves are available in a lightweight intermediate flange version. In both versions, the flange dimensions normally conform to DIN PN 10. The operating pressures are graduated according to the nominal diameters.

Design:

The design is done on a project basis, for which the following information is required:

- Air flow range (min/average/max)
- Nominal size/ pressure rating of the counter flange
- Operating pressure (min/average/max)
- Operating temperature of the medium (min/average/max)
- Ambient temperature and conditions at site
- Supply voltage/ data communication

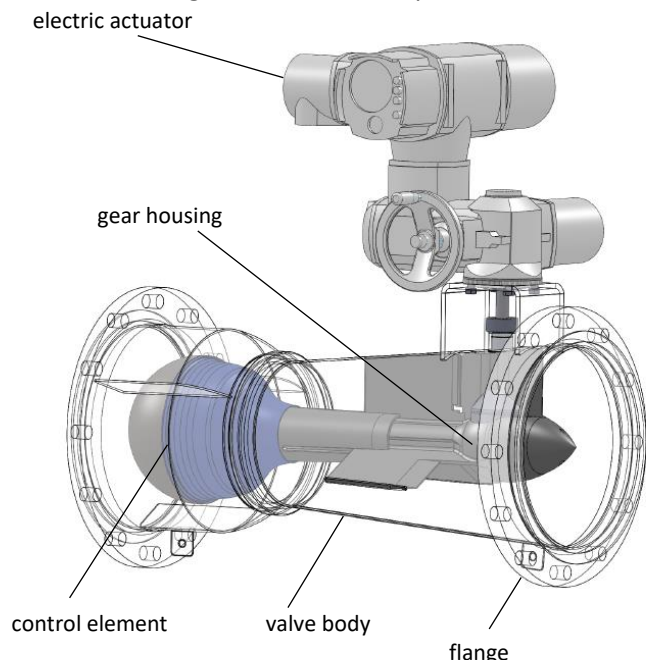

DIMENSIONS

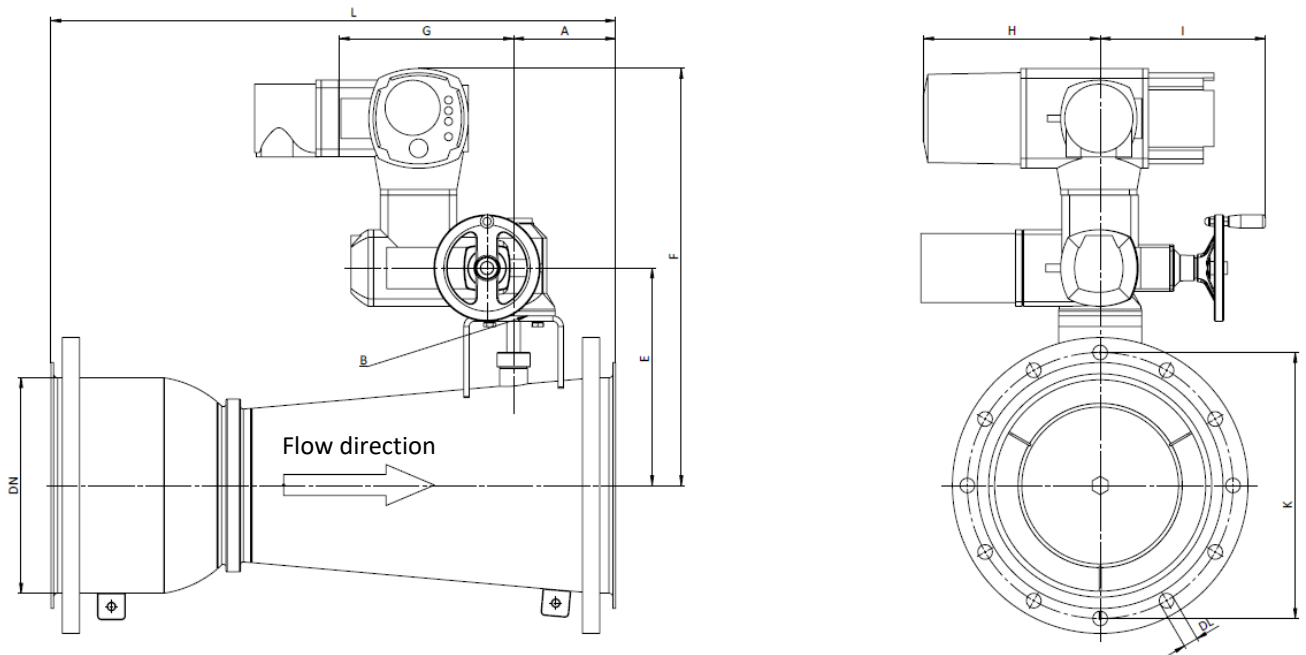

VACOMASS® jet control valve with an electric actuator VACOMASS® actuator, Type AUMA-SAR

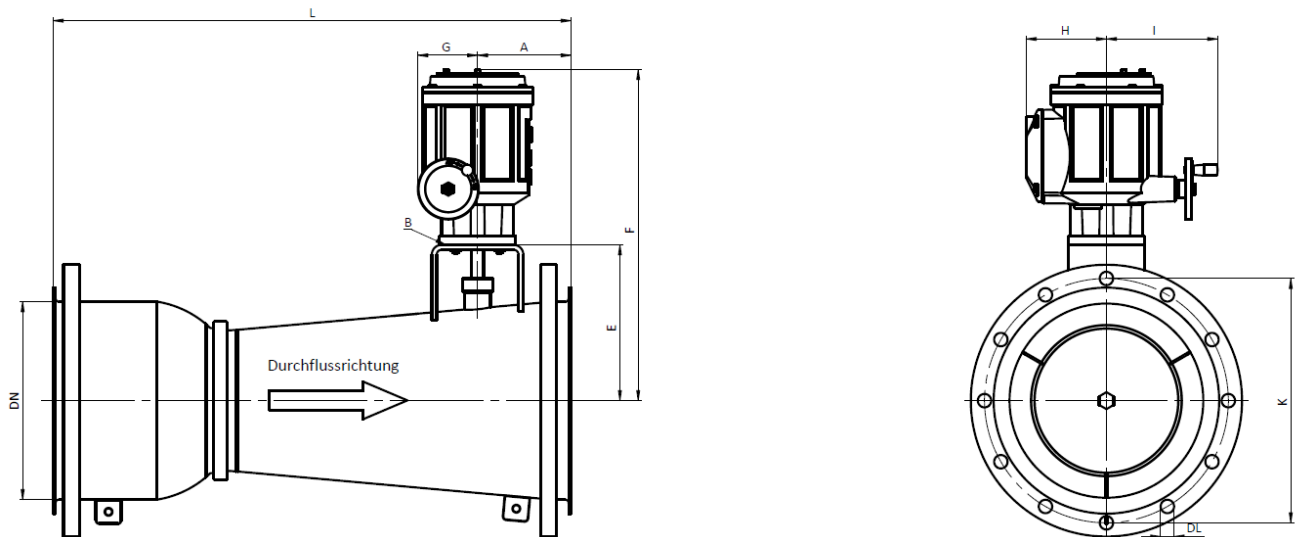

VACOMASS® jet control valve with an electric actuator VACOMASS® actuator, Type AUMA-SDM

VACOMASS® jet control valve

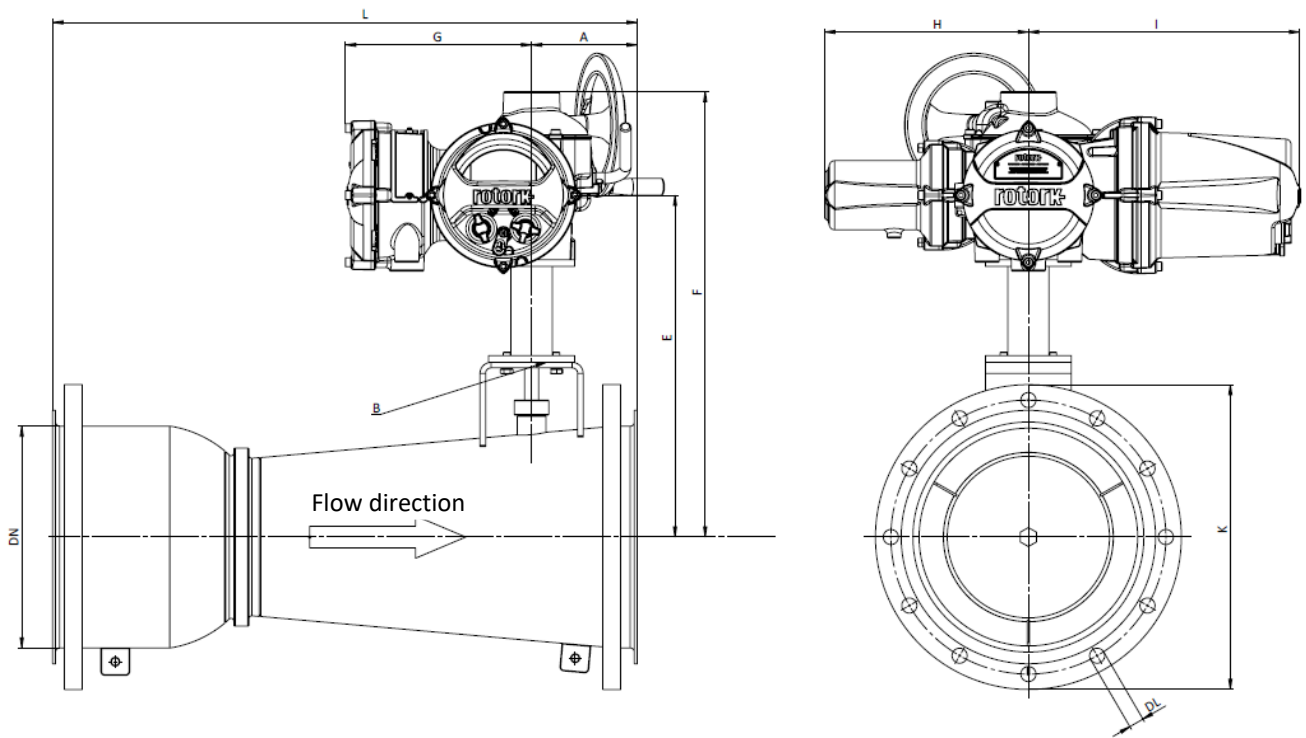

VACOMASS® jet control valve with an electric actuator VACOMASS® actuator, Type ROTORK IQM

Dimensions according to EN 1092-1/2 PN 10 Standard Flange ¹⁾											
Nominal pipe size DN	length L	A	B ¹⁾	DL	No. of holes	Weight ²⁾ kg	E	F	G	H	I
250	840	150	F10	22	12	86	depends on type of actuator				
300	850	154	F10	22	12	93					
350	900	195	F10	22	16	106					
400	970	230	F10	26	16	120					
500	1,355	215	F14	26	20	212,5					

¹⁾ ASME/ANSI flanges are also available

²⁾ according to EN ISO 5210: Industrial valves - Multi-turn valve actuator attachments

³⁾ depends on make and type of actuator (in the table SAR-AR weight is included)

Nominal pipe size DN	Recommended air flow range in Nm ³ /h (depending on temperature and pressure) ⁴⁾
250	80 - 4,000
300	100 - 7,000
350	130 - 9,000
400	160 - 11,500
500	200 - 17,000

⁴⁾ The high end of the recommended airflow range is determined by the acceptable pressure loss. Accuracy and repeatability are constant across an operating ratio of 1:100.

IMPRINT

BINDER GmbH
Buchbrunnenweg 18
89081 Ulm, Germany
Tel. +49 731 18998-0
Fax +49 731 18998-88

support@bindergroup.info
www.bindergroup.info

BIDE-M-D-VACOMASS-EN-R05 Data Sheet
VACOMASS jet control valve

Status 12/2019

All data in this product information are of actual state of the art. They are not a guarantee of certain properties of the products or their suitability for a specific application. They have no binding legal force.