

COMBIMASS[®]

Technical Data

COMBIMASS[®] eco-bio +

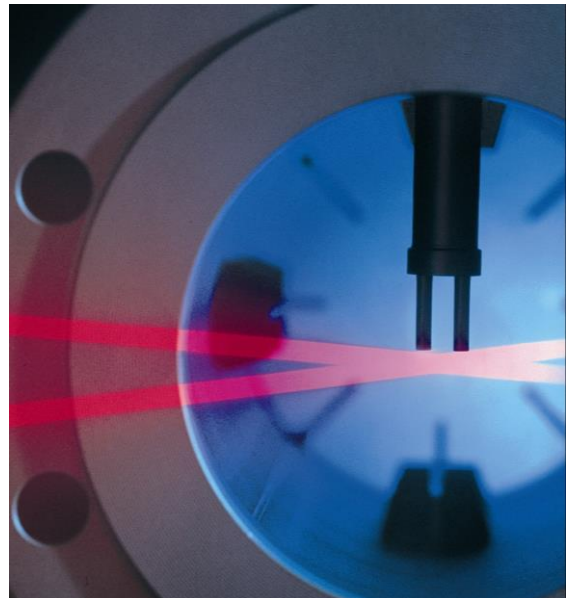

THE SYSTEM COMBIMASS®

The field transmitters of the COMBIMASS® eco series are suitable for gas flow measurement and cover a wide range of different applications. The instruments can be employed for process temperatures up to 130°C and are available in different explosion proof versions. All units of the COMBIMASS® series are characterized by high-performance digital signal processing.

The COMBIMASS® eco bio+ flowmeter is available in two different ex-versions: for the installation in ex-zone 1 with a compact and compression-proof stainless steel housing as well as for zone 2 with a cheaper aluminum housing. The electronics of the COMBIMASS®eco-bio + zone 1 is located in a dual compartment stainless steel enclosure. For transmission of the flow signal there are an isolated 4-20 mA analog output as well as a field selectable pulse output are available. Optionally a 8 digits LED display with control panel is available for both housings for the indication of actual flow rate or totalized flow as well as for field programming of the flow meter.

The COMBIMASS® eco bio+ flowmeter for the installation in biogas uses a 2-Pin-Sensor with 12 mm in diameter, which also supplies in this damp and dirty gas a stable signal. The sensor head is completely in high-grade steel manufactured and thus insensitive from a part to corrosion.

Each flow meter will be tested prior to shipment and calibrated at our CAMASS® calibration lab under actual operating conditions (piping layout, gas composition, pipe diameter, flow direction,...).

The COMBIMASS® eco bio+ flowmeter is developed particularly for the fermentation gas market using thermal dispersion technology. This principle determines directly the gas flow at standard pressure and standard temperature. Thermal dispersion technology is suited particularly well for the use in wet biogas compared to other technologies (e.g. Vortex, ultrasonic, mechanical counters), since even at small gas speeds the measurement is very precise. A further substantial advantage is that all necessary compensations can take place directly in that one measuring instrument. The installation is not more simply at lower costs, the failure probability is lower than using a combination of three measuring instruments (temperature, pressure and flow) and no error summarization will take place.

The sensor consists of a heated and a non-heated reference sensor pin. When the flowing gas is crossing the sensor, the heated one is cooling down and represents thus a measure for the number of molecules (mass flow). However the dampness portion of the biogas is measured too. Therefore the gas mass flow at standard conditions according DIN 1343 (0°C, 1.01325 bar, 0% rel. humidity) paper cannot be measured directly, since the request of 0% relative humidity is not fulfilled.

The maximum waterdamp portion at saturation point depends only on gas temperature and is represented by a well-known equation. The temperature information of the non-heated reference sensor is used to determine and compensate the humidity in the biogas directly in the electronic part of the housing. Thus the dry gas mass flow can be determined at standard conditions finally, if the installation point is chosen well at a place where gas is waterdamp saturated. If not, special additional and expensive dew-point probes must be used for humidity correction.

Further manipulation-poor designs are available, e.g. for CDM-projects.

SMART FEATURES

- Thermal flow meter for direct measurement of volumetric or gas mass flow at standard pressure and standard temperature, flow rate unaffected by pressure and temperature fluctuations
- Compact and rugged design for exceptional reliability
- Easy to install and service
- Unmatched accuracy due to digital signal processing
- Integrated humidity correction available (if gas is saturated at the installation place)
- Expandable due to modular design
- Pressure-proof dual compartment stainless steel enclosure (ATEX Ex de Zone 1) or cheap housing from aluminum (non-ATEX, Zone 2)

APPLICATIONS VERSATILITY

- Gases with methane from fermentation plants using different technologies

SPECIFICATIONS

Measuring principle	Gas flow measurement based on thermal dispersion technology
Applications	Biogas with known composition
Measured parameter	<ul style="list-style-type: none"> • Gas mass flow [kg/hr] – wet or dry • Standard volumetric flow [m_N^3/hr], if humidity correction is used • Standard flow velocity [$m_N/sec.$], if humidity correction is used
Signal processing	Microprocessor based, fully digital signal processing
Measuring mode	constant-current principle
Calibration	Biogas-calibration (gas composition given by customer) with integrated humidity correction
Enclosure	Zone 1-flowmeter: pressure-proof dual compartment housing, \varnothing 50 mm Zone 2-flowmeter: housing made from aluminum
Protection class	IP65/ IP68
Explosion protection	Zone 1: flowmeter with declaration EX de – approved acc. ATEX Zone 2: flowmeter with Manufacturer's declaration of incorporation
Ambient conditions	Ambient temperature -40°C to 80°C (-20°C to 60°C for explosion-proof flow meter), 80% Relative humidity
Power supply	18-36 VDC (power supply via standard supply units possible)
Power consumption	max. 1.1 Watt

TECHNICAL DATA

Reproducibility (electronics)	0.125% of reading
System accuracy (electronics)	0.25% of reading + 0.025% of full scale
Measuring accuracy (depending on application and calibration)	2.5% of reading + 0.2% of full scale (test bench accuracy) (1% of reading + 0.1% of full scale as an option only)
Flow range (1013 mbar, 0°C)	0.25 – 25 Nm/s (0.25 – 240 Nm/s as an option only)
Turndown ratio	Up to 100 : 1
Field display / control (option only)	<ul style="list-style-type: none"> • 8 digits, alphanumeric LED display for field indication of actual flow rate or totalized flow • Integrated totalizer • Control pad for field programming of the flowmeter using a magnetic pin • easy-to-use menu for transmitter set-up
Graphic display (optional)	<ul style="list-style-type: none"> • remote graphic display (wall or switch cabinet mounting) • simultaneous indication of flow rate and totalized flow • Integrated totalizer • touch pad for easy programming of the flowmeter • easy-to-use menu for transmitter set-up
Signal output (isolated)	<p>1 x analog output: 4-20 mA, active load < 400 Ohm 10 Bit resolution</p> <p>1 x pulse output: field selectable, max. 2 pulses/sec.</p>
Choice of sensors (option)	<p>Transmitter can be combined with different sensors of the COMBIMASS® series:</p> <p>Sensor geometry: 2 Pin (Standard for damp gases)</p> <p>Process temperature: max. 130°C</p> <p>Operating pressure: 0.9 – 1.3 bara</p> <p>Diameter of sensor rod: 12 mm</p> <p>Materials: 1.4571</p> <p>Certificates: 3.1B material certificate (as an option)</p> <p>Process connections: Compression fitting (standard)</p> <p>Hot tapping: manually operated with ball valve and further measures to sample biogas from process pipe</p>

INLET AND OUTLET STRAIGHT PIPE RUNS

General information To achieve high accuracy in flow rate measurement as specified, consideration of sufficient inlet and outlet straight pipe runs according to DIN ISO 5167-1 is crucial during installation of the flow transmitter. Reasonable measuring results can also be achieved with shortened inlet and outlet straight pipe runs according to the below specifications.

If sufficient inlet and outlet straight pipe runs are not available, please call factory. It might be possible to achieve the required measurement accuracy, if a special calibration can be carried out at our COMBIMASS® calibration centre by simulating the actual operating conditions, the range of flow rates and the piping.

Alternatively, the installation of a COMBIMASS® flow conditioner or multiple sensor may allow, to achieve accurate measuring results when space is restricted.

Reduction pieces

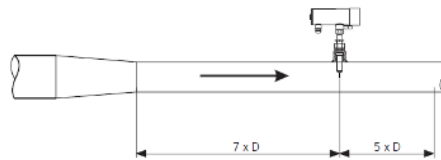

Extension pieces

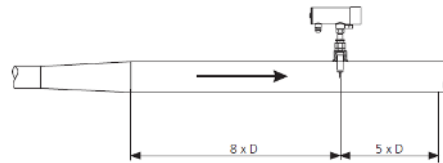

One 90° elbow

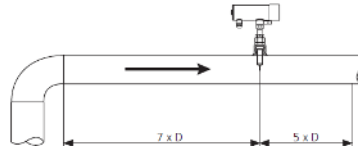

Two 90° elbows in one plane

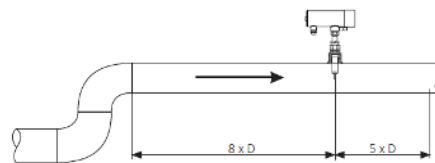

Two 90° elbows in two planes

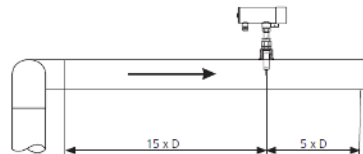

Three 90° elbows in three planes

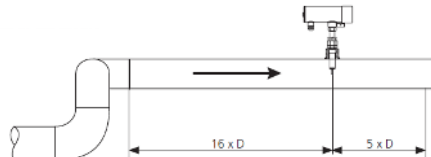

DIMENSIONS

Eco-bio+ SS with stainless steel housing for the installation in ex-zone 1 – preferred installation in wet gases in horizontal pipes from the side

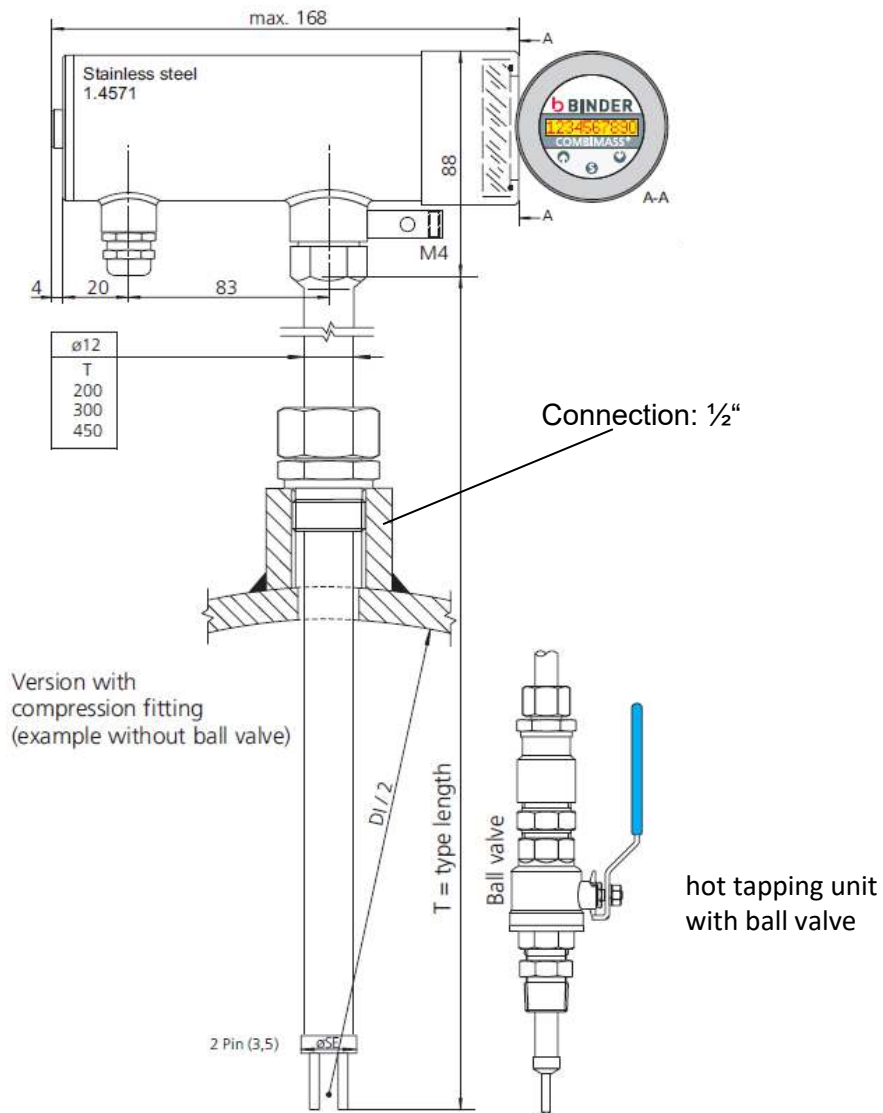

DIMENSIONS

Eco-bio+ AL with aluminum housing for the installation in ex-zone 2– preferred installation in wet gases in horizontal pipes from the side

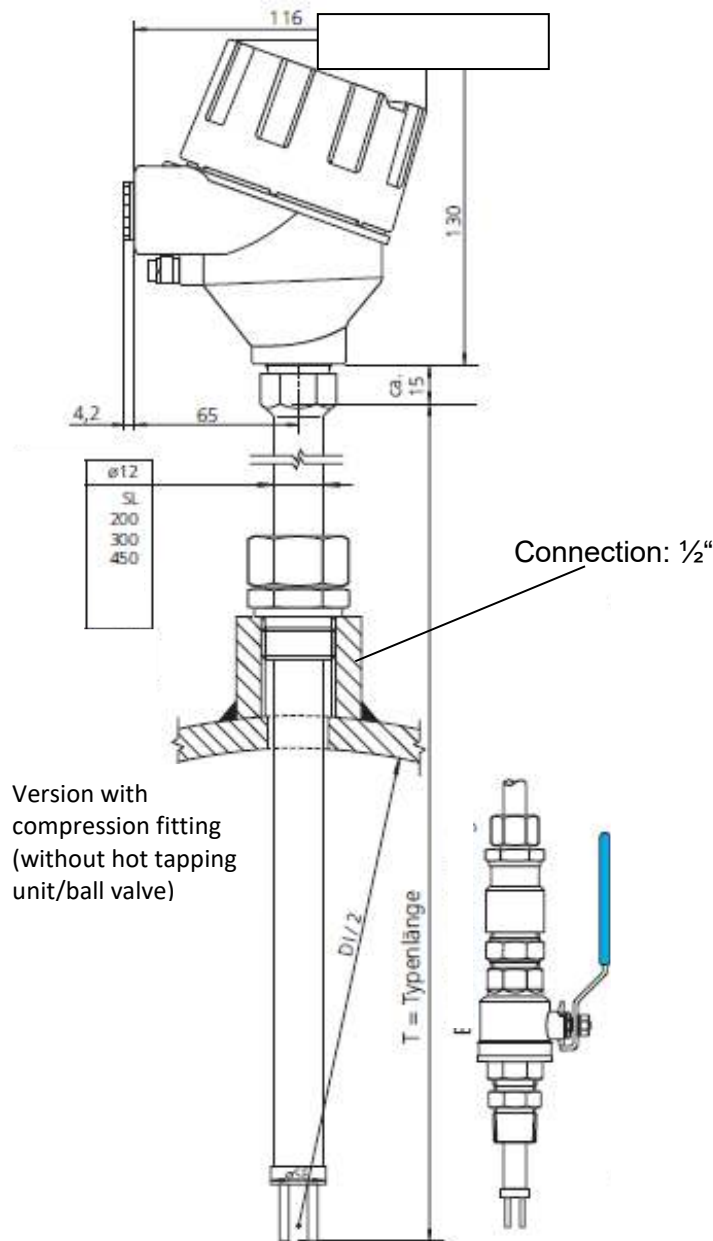

IMPRESSUM

BINDER GmbH
Buchbrunnenweg 18
89081 Ulm, Germany
Tel. +49 731 18998-0
Fax +49 731 18998-88

info@bindergroup.info
www.bindergroup.info

BIDE-M-D-COMBIMASS ECO-BIO PLUS-EN-R09
Datenblatt COMBIMASS Eco Bio Plus