

MODEL D

PRESSURE REDUCING REGULATOR

The Model D is Cashco's primary general service, self-contained, pressure reducing regulator. Unit handles inlet pressures up to 400 psig (27.6 Barg) and outlet pressures from 2-250 psig (.14-17.2 Barg) in multiple spring ranges. Model D is utilized for the majority of industrial pressure reducing applications.

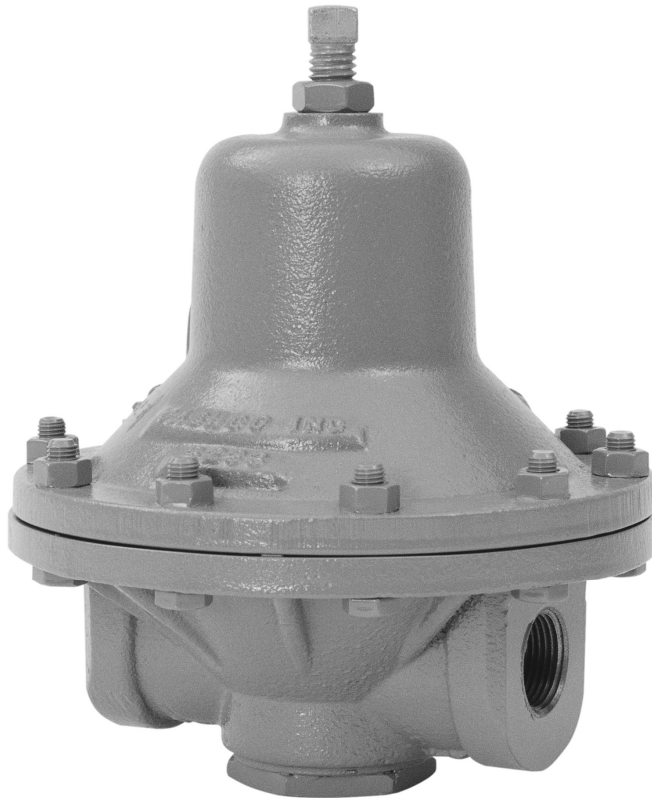

MODEL D

FEATURES

- Versatile:** Five body materials and thirty-one trim material combinations to select from.
- Tight Shutoff:** Composition seats of V-TFE, NBR, EPR, or FKM.
- Capacity:** Handles mid-range flow rates on a line size basis.
- Pressure Drop:** Handles mid-range pressure drops while maintaining good stability. Optional Stabilizer provides up to 350 psid (24.2 Bard) capability for gaseous service.
- Flow-to-Close Plug:** Incorporates the typical reducing regulator internal design.
- Incorporated Cylinder:** Plug is guided through its travel by the cylinder, which also serves to block harmful debris from entry to the seating surfaces.
- Overpressure Travel Stop:** In the event of downstream over-pressurization, diaphragm over-travel is restricted by mechanical stops.

APPLICATIONS

Used in all types of fluids, including cryogenic liquids and gases, sour gas, industrial gases, chemicals, as well as the common industrial fluids - water, oil, steam and compressed air.

STANDARD/GENERAL SPECIFICATIONS

Body Sizes: 3/8", 1/2", 3/4", 1" (DN10,15, 20, 25).
For 1-1/2" & 2" (DN40 & 50) sizes, see DL-TB.

End Connections: Standard: NPT female.
Opt-30: 150# (PN20) or 300# (PN50) RF flanges.
Opt-31: BSPT-Tapered Thread female,
Opt-31P: BSP-Parallel Thread female.
Opt-32: Extended Nipples.
Opt-34: 14" Face to Face Flange Dim.

Body/Spring Chamber/ Material Combinations: CI/CI, CI/BRZ, CI/CS, CS/CI, BRZ/BRZ, SST/CI, CS/CS, BRZ/CI, SST/CS, SST/SST
 CI = Cast grey iron
 CS = Cast carbon steel
 C-SST = Cast stainless steel
 BRZ = Cast bronze

See Table 1 for materials specifications.

Inlet Design Pressure:

Body Material	Max Pressure	
	psig	(Barg)
CI	250	(17.2)
CS, SST, BRZ	400	(27.6)

See Table 1.

Outlet Design Pressure:

Body Material	Max Pressure	
	psig	(Bard)
CI	175	(12.1)
CS, SST	300	(20.7)
BRZ	400	(27.6)

See Table 1.

Temperature: See Table 1.

Outlet Pressure: Standard: 2-150 psig (.14-10.3 Barg); in four range springs. See Tables 1 and 2.
Opt-80: 100-250 psig (6.9-17.2 Barg) spring range. BRZ body & spring chamber material only.

Pressure Drop: Standard: Up to 150 psid (10.3 Bard). Dependent on range spring selection; See Table 2a.
Opt-4: Up to 350 psid (24.2 Bard), gaseous service only.
Opt-20: Up to 250 psid (17.2 Bard) See Table 2b.

Trim Designs: Metal seated or composition seated, brass, monel, or SST materials. Metal or composition diaphragms. See Tables 3 and 4.

Capacities: Up to 3.6 Cv; see Table 7 for Cv vs. outlet pressure vs. body size vs. diaphragm material. Flow tables — Water - Table 8. Compressed Air - Table 9. Steam - Table 10.

For wide open Cv's, see Table 6 ; use for safety relief sizing.

Seat Leakage: Meets ANSI/FCI 70-2.
Standard: Metal seated, Class IV.
Optional: Composition (soft) seated Class VI.

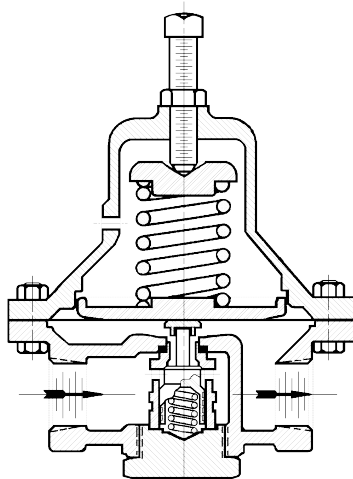

Figure 1: Metal Seat Design

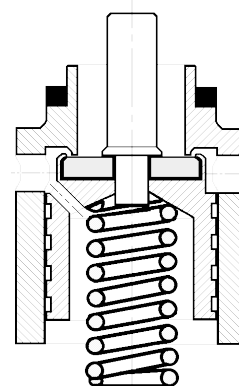

Figure 2: Composition Seat Design

Gaskets: Standard: Graphite/NBR.
- Cylinder & Diaphragm Gaskets.
NOT SUITABLE FOR OXYGEN SERVICE.

(**NOTE:** Composition diaphragms do not use a diaphragm gasket.)

Alternate Material: See Opt-45.

Cryogenic: See Opt-5 and -36.

Range Springs: Standard: Epoxy coated steel.
LCC Body material: SST.
Cryogenic: SST.

Flange Bolting: Standard: Zinc plated, heat treated steel.

LCC Body material: SST.

Cryogenic Construction: SST.

Painting: Standard: All non-corrosion resistant portions to be painted with corrosion resistant epoxy paint per Cashco Spec #S-1606.

OPTION SPECIFICATIONS

Option -3: HANDWHEEL & LOCKING LEVER. Utilize when P₂ pressure setting changes are frequent.

Option -4: STABILIZER. Recommended for gaseous, vapor, and steam service only. Stabilizer provides added guiding to maximize stability for internal trim, allowing improved pressure drop capability. Stabilizer materials are SST/TFE. For use with all trim designation numbers. See Table 2 for application recommendations.

Option -5: BRZ CRYOGENIC CONSTRUCTION. BRZ/BRZ body/spring chamber materials. NPT end connections. BO, and B5 trim selections only. SST flange bolting and range spring; remaining parts of brass or bronze materials. TFE-silicate gaskets. 1/8" (DN6) NPT tapped spring chamber vent/purge connection. Drilled condensate drain hole near adjusting screw. Cleaned and packaged for oxygen service per Cashco cleaning specification #S-1134. Applicable temperature range -325° to +150° F (-198° to +66° C). **NOTE:** Design requires that spring chamber be mounted pointing downwards in a horizontal pipe. See Figure 3.

Option -20: AIR PRESSURE LOADED. No range spring. Use when the outlet pressure is frequently changed. Composition Diaphragm ONLY. Incorporates a cast bronze or cast steel loading chamber with 1/4" NPT loading connection for external pressure loading up to 210 psig (14.4 Barg). Sizes 3/8" thru 1" only. Available in Brass and SST Trim with Monel pusher plate.

Option -25: TAPPED VENT. 1/8" (DN6) NPT tapped opening in spring chamber for piping vent to remote location, in the event of diaphragm failure.

Option -25P: PLASTIC RAIN PROOF BUG VENT. (For Opt-25).

Option -25S: SST RAIN PROOF BUG VENT: (For Opt-25).

Option -30: FLANGED END CONNECTIONS. CS or SST body materials only. Flange and pipe nipple materials of same general chemistry as body material. Available in 150# RF or 300# RF flanges only. Not available 3/8" (DN10) body size.

NOTES:

1. The body P vs. T ratings of Table 1 are the limiting variables for flanged end connections, unless further restricted by ASME B16.5.

Option -31: BSPT END CONNECTIONS. British Standard Tapered Pipe threads per ISO 7/1; used as an alternate to NPT ends. Not available 3/8" (DN10) body size.

Option -31P: BSPP END CONNECTIONS. British Standard Parallel Pipe threads per ISO 7/1; used as an alternate to NPT ends. Not available 3/8" (DN10) body size.

Option -32: EXTENDED PLAIN END NIPPLES. Schedule 80 plain end extension nipples available for carbon steel or 316 SST bodies. Nipples of same basic material as body. **NOTE:** Not available 3/8" (DN10) body size.

- Option -34:** SPECIAL 14" FACE TO FACE DIMENSION FOR FLANGED END CONNECTIONS, Sizes 1/2" - 1" only. See Opt.-30 for standard face to face dimension.
- Option -36:** SST CRYOGENIC CONSTRUCTION. Same specifications as Option -5, except:
a. For SST/SST body/spring chamber materials.
b. S1, and S36 only available trim selections.
- Option -37:** ALL SST/CLEAN UNIT FOR LIQUIDS & GASES, 1/2", 3/4" and 1" (DN 15, 20, & 25) NPT sizes only. Uses 316 SST body and spring chamber, S6 trim only. SST T-handle, spring button, spring, pressure plate, nuts and bolts. All wetted and external castings are electropolished and unit is cleaned to Cashco Specification #S-1576. Suitable for fluids of -20 to 100° F (-29 to 38° C); inlet pressures to 250 psig (17.2 Barg) and outlet pressures adjustable from 2 to 80 psig (.14 to 5.5 Barg) with multiple range springs. Complete with 1/4" (DN8) NPT output gauge connection body tap and 1-1/2" (40 mm) diameter SST pressure gauge, 0-100 psig (0-6.9 Barg).
- Option -37S:** ALL SST/CLEAN UNIT FOR STEAM. Similar to Option -37, except uses S1 trim with graphite diaphragm gasket. Does not include gauge connection or gauge. Suitable for steam/condensate service up to 350° F (177° C), inlet pressures to 100 psig (6.9 Barg). Outlet pressures adjustable from 2 to 80 psig (.14 to 5.5 Barg) with multiple range springs.
- Option -40:** CS NACE CONSTRUCTION. Internal wetted portions meet NACE standard MR0175, when exterior of the regulator is not directly exposed to a sour gas environment, buried, insulated or otherwise denied direct atmospheric exposure. CS/CS body/spring chamber material with S40, S40T, and S40V only trim. (Alternate LCC body/spring chamber material with S40B and S40C only trim.) Available all sizes, except 3/8" (DN10).
- Option -40SST:** SST NACE CONSTRUCTION. Same as Opt-40, except uses SST/SST body/spring chamber construction.
- Option -45:** TFE GASKETS. Primarily for oxygen service. Utilizes TFE silicate diaphragm and cylinder gasket over standard gaskets. Temperature range -20° to +400° F (-29° to +205° C).
- Option -55:** SPECIAL CLEANING. SST and BRZ body materials ONLY. Cleaning per Cashco Spec. #S-1134 for Oxygen Service. **NOTE:** Design Pressure Rating shall not exceed 375 psig (25.8 Barg) when body material is SST and process medium is oxygen.
- Option -56:** SPECIAL CLEANING. All body materials. Cleaning per Cashco Spec. #S-1542. Cleaning identical to that of Opt-55, but not labeled for application in oxygen service. NOT suitable for Oxygen Service.
- Option -80:** HIGH OUTLET PRESSURE. BRZ spring chamber only. (**NOTE:** Taller spring chamber; see dimension tables.) Spring covers 100-250 psig (6.9-17.2 Barg) pressure range. Apply with BRZ, body materials only and metal diaphragm trims only.
- Option -85:** ONE 1/8" (DN6) NPT TAP. Located on body outlet for gauge connection.
- Option -87:** TWO 1/8" (DN6) NPT TAPS. One located on the inlet, one on the outlet for gauge connections for Opt-34 only.

TECHNICAL SPECIFICATIONS

TABLE 1 DESIGN PRESSURE - TEMPERATURE MATERIAL SPECIFICATIONS

STANDARD CONSTRUCTION									
Material Specifications Body - Spring or Loading Chamber (Body Cap)		ENGLISH				METRIC			
		Inlet		Outlet		Inlet		Outlet	
		Pressure	Temperature†	Pressure	Temperature†	Pressure	Temperature†	Pressure	Temperature†
Descript (Abbr.)	ASTM No.	psig	°F	psig	°F	Barg	°C	Barg	°C
CI - CI (SST) ‡	A126, Class B (A479 Alloy S31600/3)	250	-20 to +400	175	-20 to +400	17.2	-29 to +205	12.1	-29 to +205
CI- BRZ (SST)	A126, Class B - B62, Alloy C83600(A479 Alloy S31600/3)								
CI- CS (SST)	A126, Class B - A216, Gr. WCB (A479 Alloy S31600/3)								
BRZ- CI (BRASS)	B62, Alloy C83600-A126, Class B (B16, Alloy 360)	250	-20 to +350	175	-20 to +350	17.2	-29 to +176	12.1	-29 to +176
CS CI (SST)	A216, Gr. WCB A126, Class B (A479 Alloy S31600/3)	250	-20 to +400	175	-20 to +400	17.2	-29 to +205	12.1	-29 to +205
SST CI (SST)	A351, Gr. CF8M A126, Class B (A479 Alloy S31600/3)								
BRZ - BRZ (BRASS)	B62, Alloy C83600 (B16, Alloy 360)	400	-20 to +200	400	-20 to +200	27.6	-29 to +94	27.6	-29 to +94
		390	300	390	300	26.9	149	26.9	149
		315	350	315	350	21.7	176	21.7	176
CS - CS ** (SST)	A216, Gr. WCB (A479 Alloy S31600/3)	400	-20 to +400	300	-20 to +400	27.6	-29 to +205	20.7	-29 to +205
SST - SST *** (SST)	A351, Gr. CF8M (A479 Alloy S31600/3)	400	-20 to +400	300	-20 to +400	27.6	-29 to +205	20.7	-29 to +205
SST CS (SST)	A351, Gr. CF8M A216, Gr. WCB (A479 Alloy S31600/3)								
Options -5 and -36 CRYOGENIC CONSTRUCTION									
BRZ - BRZ (BRASS)	B62, Alloy C83600 (B16, Alloy 360)	400	-325 to +150	400	-325 to +150	27.6	-198 to +66	27.6	-198 to +66
SST - SST (SST)	A351, Gr. CF8M (A479 Alloy S31600/3)	400	-325 to +150	300	-325 to +150	27.6	-198 to +66	20.7	-198 to +66
<p>NOTE: Certification of material chemical and physical properties are not available for CI or for diaphragm sheet material. ‡ See Table 5 restrictions for use with Fuel Oil and Hydrocarbon Gas or Liquid applications. †Design temperature range of the regulator may be limited by trim selection. See Table 3, 4a and 4b. ** Alternate material - LCC - LCC Steel - ASTM A352 Gr. LCC minimum temperature -50 °F (-46 °C) with S1, S36, S40B or S40C Trim *** Minimum temperature -50 °F (-46 °C) with S40B or S40C Trim.</p>									

TABLE 2a RANGE SPRINGS WITH RECOMMENDED PRESSURE DROPS

Construction	Range spring		Recommended Max Pressure Drop*	
	psig	(Barg)	psid	(Bard)
Standard or Cryogenic	2-15	(.14-1.0)	100	(6.9)
	10-40	(.69-2.8)	125	(8.6)
	30-80	(2.1-5.5)	150	(10.3)
	70-150	(4.8-10.3)		
w/Opt-80	100-250	(6.9-17.2)	200	(13.8)
w/Stablizer Opt-4	2-15	(.14-1.0)		
	10-40	(.69-2.8)		
	30-80	(2.1-5.5)		
w/Opt-4+80	70-150	(4.8-10.3)	350	(24.2)
	100-250	(6.9-17.2)		

***NOTES:**
 1. For steam service, B0 & B1 trim designation nos. are limited to 100 psid (6.9 Bard).
 2. Opt.-4 Stabilizer is recommended only for gaseous service with critical or "choked" flow. This flow occurs when P_{1Abs} / P_{2Abs} is greater than 2.0. Otherwise use Standard or Cryogenic construction.

TABLE 2b MAX DIAPHRAGM RATING *

Composition Diaphragm Material	Body Size			
	3/8" - 1/2"		3/4" - 1"	
	psig	(Barg)	psig	(Barg)
FKM	100	(6.9)	200	(13.8)
Gylon	50	(3.4)	50	(3.4)
FK	250	(17.2)	250	(17.2)
Neoprene	100	(6.9)	100	(6.9)
EPDM	100	(6.9)	200	(13.8)

* Opt-20 Max Loading pressure up to 210 psig (14.4 Barg).

**TABLE 3
BRASS TRIM MATERIAL COMBINATIONS**

PART	BRASS TRIM #								
	METAL SEAT		COMPOSITION SEAT						
	B01*	B1 *	B2 (Air/H ₂ O)	B3	B4	B5 ¹ (Oxygen)	BB (Fuel-Oils)	BJ	BK
Diaphragm	Phos Brz	302 SST	BC	BC	FKM	Phos Brz	NBR	FK	FKM
Cylinder	Brass	Brass	Brass	Brass	Brass	Brass	Brass	Brass	Brass
Piston	Brass	Brass	Brass	Brass	Brass	Brass	Brass	Brass	Brass
Seat Disc	None (Metal)	None (Metal)	NBR	V-TFE	V-TFE	V-TFE	NBR	V-TFE	FKM
Piston Spring	302 SST	302 SST	Phos Brz	Phos Brz	302 SST	Phos Brz	Phos Brz	Phos. Brz.	Phos. Brz.
Pusher Plate	Brass	Brass	Brass	Brass	Brass	Brass	Brass	Brass	Brass
Temperature Range	-20 to +500°F -29 to +260°C	-20 to +400°F -29 to +205°C	-20 to +180°F -29 to +83°C	-20 to +180°F -29 to +83°C	-20 to +300°F -29 to +149°C	-20 to +200°F -29 to +94°C	-20 to +180°F -29 to +83°C	-20 to +350°F -29 to +177°C	-20 to +300°F -29 to +149°C

* Max pressure drop = 100 psid (6.9 Bard).
¹ For cryogenic applications; B0 or B5 trim designations ONLY are allowed for -325° to +150°F (-198° to +66°C) range.

**TABLE 4(a)
MONEL & STAINLESS STEEL TRIM MATERIAL COMBINATION – METAL SEAT**

PART	STAINLESS STEEL TRIM #							MONEL TRIM #
	S0	S1 ¹	S2 (Steam)	S2N	SG	S40 (NACE)	S40B (NACE)	M1
Diaphragm	TFE Coated 302 SST	302 SST	302 SST	BC	Gylon	BC	BC *	302 SST
Cylinder	316 SST	316 SST	416 SST	416 SST	416 SST	316 SST	316SST	Monel
Piston	316 SST	316 SST	416 SST	416 SST	416 SST	316 SST	316SST	Monel
Seat Disc	None (Metal)	None (Metal)	None (Metal)	None (Metal)	None (Metal)	None (Metal)	None (Metal)	None (Metal)
Piston Spring	302 SST	302 SST	302 SST	302 SST	302 SST	Inconel X-750	Inconel X-750	302 SST
Pusher Plate	316 SST	316 SST	316 SST	316 SST	Monel	316 SST	316SST	316 SST
Temperature Range	-20 to +400°F -29 to +205°C		-20 to +180°F -29 to +83°C	-20 to +400°F -29 to +205°C	-20 to +180°F -29 to +83°C	-50 to +250°F -46 to +121°C	-20 to +400°F -29 to +205°C	

¹ For cryogenic applications; S1 and S36 trim designations are ONLY allowed for -325° to +150°F (-198° to +66°C) range.
 Cashco Inc. does not recommend metal seated trim on any service where the flow will be dead ended down stream of the pressure reducing regulator
 * Special BC Material for Low Temperature.

**TABLE 4(b)
MONEL & STAINLESS STEEL TRIM MATERIAL COMBINATION – COMPOSITION (SOFT) SEAT**

PART	STAINLESS STEEL TRIM #												MONEL TRIM #	
	S3	S4	S4N (Air/H ₂ O)	S6 (Hot Air/H ₂ O)	S7	S9	S36 ¹	S40T (NACE)	S40V (NACE)	S40C (NACE)	SB	SJ	SK	M36
Diaphragm	BC	BC	BC	EPDM	FKM	TFE Coated 302 SST	302 SST	FKM	FKM	BC *	NBR	FK	FKM	302 SST
Cylinder	316 SST	416 SST	416 SST	316 SST	316 SST	316 SST	316 SST	316 SST	316 SST	316 SST	416 SST	316 SST	316 SST	Monel
Piston	316 SST	416 SST	416 SST	316 SST	316 SST	316 SST	316 SST	316 SST	316 SST	316 SST	416 SST	316 SST	316 SST	Monel
Seat Disc	V-TFE	V-TFE	NBR	EPR	V-TFE	V-TFE	V-TFE	V-TFE	FKM	V-TFE	NBR	V-TFE	FKM	V-TFE
Piston Spring	302 SST	302 SST	302 SST	302 SST	302 SST	302 SST	302 SST	Inconel X-750	Inconel X-750	Inconel X-750	302 SST	302 SST	302 SST	302 SST
Pusher Plate	316 SST	316 SST	316 SST	316 SST	316 SST	316 SST	316 SST	316 SST	316 SST	316 SST	316 SST	316 SST	316 SST	316 SST
Temp Range	-20 to +180°F -29 to +83°C		-20 to +300°F -29 to +149°C	-20 to +400°F -29 to +205°C	-20 to +300°F -29 to +149°C	-50 to +250°F -46 to +121°C	-20 to +180°F -29 to +83°C	-20 to +350°F -29 to +177°C	-20 to +300°F -29 to +149°C	-20 to +400°F -29 to +205°C				

¹ For cryogenic applications; S1 and S36 trim designations are ONLY allowed for -325° to +150°F (-198° to +66°C) range.
 * Special BC Material for Low Temperature.

= Most common use - See Table 5

ABBREVIATIONS

NBR = Buna-N BC = Neoprene EPDM = Ethylene Propylene Diene EPR = Ethylene Propylene TFE = Polytetrafluoroethylene
 FK = Fluorosilicone FKM = Fluorocarbon elastomer V-TFE = Virgin TFE Phos BRZ = Phosphor Bronze

**TABLE 5
APPLICATIONS**

FLUID	RECOMMENDED CONSTRUCTION	TRIM DESIGNATION #
Air or Inert Gases	Composition Seat and Diaphragm Metal Seat and Composition Diaphragm Metal Seat and Diaphragm	B2, B3, B4, SB, S4N S2N B0, B1
Oxygen	Composition Seat and Diaphragm Composition Seat and Metal Diaphragm Metal Seat and Diaphragm	B4, BJ, BK, S7, SJ, SK B5, S36 S1
Oxygen above 290 psid	Metal Seat and Diaphragm TFE Seat and Metal Diaphragm	M1 M36
Chemicals	Metal Seat and Diaphragm Metal Seat and Composition Diaphragm Composition Seat and Diaphragm TFE seat and Metal Diaphragm	S1, S2, S0 S40 SB, S3, S4, SK, S4N, S6 or S40T, S9
Sour Gas	Metal Seat and Composition Diaphragm Composition Seat and Diaphragm	S40 (* S40B) S40T, S40V (* S40C)
Cryogenic Gas or Liquids	TFE Seat and Metal Diaphragm Metal Seat and Diaphragm	B5 or S36 B0 or S1
Fuel Oil‡	Composition Seat and Diaphragm	BB, BK, B4, SB, SK, S3, S4, or S4N
Hydrocarbon Gas or Liquids‡	Composition Seat and Diaphragm	BB, BK, B3, B4, SK, S3, S4, or S4N
Saturated Steam, Low Pressures - up to 50 psig (3.4 Barg)	Metal Seat and Diaphragm Metal Seat and Composition Diaphragm Composition Seat and Diaphragm	S2, B0, or S1 SG S6
Saturated Steam, Pressures up to 100 psig (6.8 Barg) 50 psid (3.4 Barg)	Metal Seat and Diaphragm Metal Seat and Composition Diaphragm	S2, B0, B1 or S1 SG
Steam Pressures above 100 psig (6.9 Barg) Saturated or Superheated	Metal Seat and Diaphragm	S2 or S1
Water and Condensate Low Temperature – 32–180°F (0–83°C)	Composition Seat and Diaphragm Metal Seat and Composition Diaphragm Metal Seat and Diaphragm	B2, B3, BB, SB, S3, S4, or S6, S4N S2N S1, S2
Water and Condensate High Temperature – 180–300°F (83–149°C)	Metal Seat and Diaphragm	S1 or S2
<p>NOTE 1: Trim Designation Nos. in "boldface" are the most commonly used. Cashco, or its representatives may make recommendations or suggestions as to the suitability of certain trims for specific services. These are trims that have been used successfully in the past in similar applications. However, the user has final responsibility for materials selected.</p> <p>NOTE 2: Cashco, Inc. does not recommend metal seated trim on any service where the flow will be dead ended down stream of the pressure reducing regulator.</p>		
<p>‡ In accordance with ASME B31.3 "process piping", do not use Cast Iron Body for hydrocarbon or flammable fluid service with inlet pressures greater than 150 psig (10.3 Barg) or temperatures greater than 300° F (149° C).</p> <p>* NACE Trims for use w/ LCC Body Material Temperature Range -50 to +250°F (-46 to +121°C).</p>		

**TABLE 6
MAXIMUM C_v WITH PLUG WIDE OPEN
(Use for Relief Valve Sizing)**

Body Size		Cv
Inch	(DN)	
3/8"	(10)	1.8
1/2"	(15)	1.8
3/4"	(20)	3.7
1"	(25)	4.0
METRIC CONVERSION FACTOR: Cv / 1.16 =kv		

**TABLE 7
CAPACITY - Cv
AT FLOWING PRESSURE
(FL = 0.95)**

METAL DIAPHRAGM							
Flowing Pressure		3/8" (DN10) Body			1/2" (DN15) Body		
		%Droop			%Droop		
psig	(Barg)	10%	20%	30%	10%	20%	30%
5	(0.3)	0.11	0.22	0.34	0.11	0.22	0.34
10	(0.7)	0.22	0.45	0.67	0.22	0.45	0.67
15	(1.0)	0.34	0.67	1.01	0.34	0.67	1.01
25	(1.7)	0.28	0.57	0.85	0.28	0.57	0.85
35	(2.4)	0.40	0.79	1.19	0.40	0.79	1.19
50	(3.4)	0.26	0.52	0.77	0.26	0.52	0.77
75	(5.2)	0.39	0.77	1.16	0.39	0.77	1.16
100	(6.9)	0.28	0.56	0.83	0.28	0.56	0.83
135	(9.3)	0.37	0.76	1.12	0.37	0.76	1.12
150	(10.3)	0.42	0.83	1.25	0.42	0.83	1.25
175	(12.1)	0.53	1.06	1.59	0.53	1.06	1.59
200	(13.8)	0.61	1.21	1.80	0.61	1.21	1.80
225	(15.5)	0.68	1.37	1.80	0.68	1.37	1.80
250	(17.2)	0.76	1.52	1.80	0.76	1.52	1.80

COMPOSITION DIAPHRAGM							
Flowing Pressure		3/8" (DN10) Body			1/2" (DN15) Body		
		%Droop			%Droop		
psig	(Barg)	10%	20%	30%	10%	20%	30%
5	(0.3)	0.16	0.31	0.47	0.16	0.31	0.47
10	(0.7)	0.31	0.63	0.94	0.31	0.63	0.94
15	(1.0)	0.47	0.94	1.41	0.47	0.94	1.41
25	(1.7)	0.40	0.81	1.21	0.40	0.81	1.21
35	(2.4)	0.56	1.13	1.69	0.56	1.13	1.69
50	(3.4)	0.36	0.71	1.07	0.36	0.71	1.07
75	(5.2)	0.54	1.07	1.61	0.54	1.07	1.61
100	(6.9)	0.35	0.71	1.06	0.35	0.71	1.06
150	(10.3)	0.53	1.06	1.59	0.53	1.06	1.59
175	(12.1)	0.53	1.06	1.59	0.53	1.06	1.59
200	(13.8)	0.61	1.21	1.80	0.61	1.21	1.80
225	(15.5)	0.68	1.37	1.80	0.68	1.37	1.80
250	(17.2)	0.76	1.52	1.80	0.76	1.52	1.80

METAL DIAPHRAGM							
Flowing Pressure		3/4" (DN20) Body			1" (DN25) Body		
		%Droop			%Droop		
psig	(Barg)	10%	20%	30%	10%	20%	30%
5	(0.3)	0.18	0.35	0.53	0.18	0.35	0.53
10	(0.7)	0.35	0.70	1.05	0.35	0.70	1.05
15	(1.0)	0.53	1.05	1.58	0.53	1.05	1.58
25	(1.7)	0.44	0.88	1.32	0.44	0.88	1.32
35	(2.4)	0.62	1.23	1.85	0.62	1.23	1.85
50	(3.4)	0.49	0.98	1.48	0.49	0.98	1.48
75	(5.2)	0.74	1.48	2.22	0.74	1.48	2.22
100	(6.9)	0.54	1.08	1.62	0.54	1.08	1.62
135	(9.3)	0.73	1.46	2.19	0.73	1.46	2.19
150	(10.3)	0.81	1.62	2.43	0.81	1.62	2.43
175	(12.1)	1.24	2.47	3.60	1.24	2.47	3.60
200	(13.8)	1.41	2.82	3.60	1.41	2.82	3.60
225	(15.5)	1.59	3.18	3.60	1.59	3.18	3.60
250	(17.2)	1.77	3.60	3.60	1.77	3.60	3.60

COMPOSITION DIAPHRAGM							
Flowing Pressure		3/4" (DN20) Body			1" (DN25) Body		
		%Droop			%Droop		
psig	(Barg)	10%	20%	30%	10%	20%	30%
5	(0.3)	0.34	0.67	1.01	0.34	0.67	1.01
10	(0.7)	0.67	1.34	2.02	0.67	1.34	2.02
15	(1.0)	1.01	2.02	3.03	1.01	2.02	3.03
25	(1.7)	0.89	1.79	2.68	0.89	1.79	2.68
35	(2.4)	1.25	2.51	3.60	1.25	2.51	3.60
50	(3.4)	1.15	2.31	3.60	1.15	2.31	3.60
75	(5.2)	1.73	3.20	3.60	1.73	3.20	3.60
100	(6.9)	1.03	2.06	3.60	1.03	2.06	3.60
150	(10.3)	1.54	3.09	3.60	1.37	2.74	3.60
200	(13.8)	1.56	3.13	3.60	1.56	3.13	3.60
225	(15.5)	1.76	3.50	3.60	1.76	3.50	3.60
250	(17.2)	1.95	3.60	3.60	1.95	3.60	3.60

METRIC CONVERSION FACTOR: Cv / 1.16 =kv

TABLE 8
WATER CAPACITIES - GPM
S.G. = 1.0 T = 60°F F_L = 0.95
Composition Diaphragm Only

P2 Outlet Pressure		P1 Inlet Pressure		3/8" (DN10) Body Size			1/2" (DN15) Body Size			3/4" (DN20) Body Size			1" (DN25) Body Size			
psig	(Barg)	psig	(Barg)	10%	20%	30%	10%	20%	30%	10%	20%	30%	10%	20%	30%	
5	(34)	25	(1.7)	0.7	1.4	2.1	0.7	1.4	2.1	1.5	3.0	4.5	1.5	3.0	4.5	
		50	(3.4)	1.1	2.1	3.2	1.1	2.1	3.2	2.3	4.5	6.8	2.3	4.5	6.8	
		75	(5.2)	1.3	2.6	3.9	1.3	2.6	3.9	2.8	5.6	8.5	2.8	5.6	8.5	
		100	(6.9)	1.6	3.0	4.6	1.6	3.0	4.6	3.3	6.5	9.8	3.3	6.5	9.8	
		125	(8.6)	HI DP	HI DP	HI DP	HI DP	HI DP	HI DP	HI DP	HI DP	HI DP	HI DP	HI DP	HI DP	HI DP
10	(69)	25	(1.7)	1.2	2.4	3.6	1.2	2.4	3.6	2.6	5.2	7.8	2.6	5.2	7.8	
		50	(3.4)	2.0	4.0	5.9	2.0	4.0	5.9	4.2	8.5	12.8	4.2	8.5	12.8	
		75	(5.2)	2.5	5.1	7.6	2.5	5.1	7.6	5.4	10.8	16.3	5.4	10.8	16.3	
		100	(6.9)	2.9	6.0	8.9	2.9	6.0	8.9	6.4	12.7	19.2	6.4	12.7	19.2	
		125	(8.6)	HI DP	HI DP	HI DP	HI DP	HI DP	HI DP	HI DP	HI DP	HI DP	HI DP	HI DP	HI DP	HI DP
15	(1.0)	25	(1.7)	1.5	3.0	4.5	1.5	3.0	4.5	3.2	6.4	9.6	3.2	6.4	9.6	
		50	(3.4)	2.8	5.6	8.3	2.8	5.6	8.3	6.0	12.0	17.9	6.0	12.0	17.9	
		75	(5.2)	3.6	7.3	10.9	3.6	7.3	10.9	7.8	15.6	23.5	7.8	15.6	23.5	
		100	(6.9)	4.3	8.7	13.0	4.3	8.7	13.0	9.3	18.6	27.9	9.3	18.6	27.9	
		125	(8.6)	HI DP	HI DP	HI DP	HI DP	HI DP	HI DP	HI DP	HI DP	HI DP	HI DP	HI DP	HI DP	HI DP
25	(1.7)	50	(3.4)	2.0	4.1	6.1	2.0	4.1	6.1	4.5	9.0	13.4	4.5	9.0	13.4	
		75	(5.2)	2.8	5.7	8.6	2.8	5.7	8.6	6.3	12.7	19.0	6.3	12.7	19.0	
		100	(6.9)	3.5	7.0	10.5	3.5	7.0	10.5	7.7	15.5	23.2	7.7	15.5	23.2	
		125	(8.6)	4.0	8.1	12.1	4.0	8.1	12.1	8.9	17.9	26.8	8.9	17.9	26.8	
		150	(10.3)	4.5	9.1	13.5	4.5	9.1	13.5	10.0	20.0	30.0	10.0	20.0	30.0	
35	(2.4)	75	(5.2)	3.5	7.1	10.7	3.5	7.1	10.7	7.9	15.9	22.8	7.9	15.9	22.8	
		100	(6.9)	4.5	9.1	13.6	4.5	9.1	13.6	10.1	20.2	29.0	10.1	20.2	29.0	
		125	(8.6)	5.3	10.7	16.0	5.3	10.7	16.0	11.9	23.8	34.2	11.9	23.8	34.2	
		150	(10.3)	6.0	12.1	18.1	6.0	12.1	18.1	13.4	26.9	38.6	13.4	26.9	38.6	
		175	(12.1)	HI DP	HI DP	HI DP	HI DP	HI DP	HI DP	HI DP	HI DP	HI DP	HI DP	HI DP	HI DP	HI DP
50	(3.4)	75	(5.2)	1.8	3.6	5.4	1.8	3.6	5.4	5.8	11.6	18.0	5.8	11.6	18.0	
		100	(6.9)	2.5	5.0	7.6	2.5	5.0	7.6	8.1	16.3	25.5	8.1	16.3	25.5	
		125	(8.6)	3.1	6.1	9.3	3.1	6.1	9.3	10.0	20.0	31.2	10.0	20.0	31.2	
		150	(10.3)	3.6	7.1	10.7	3.6	7.1	10.7	11.5	23.1	36.0	11.5	23.1	36.0	
		175	(12.1)	4.0	7.9	12.0	4.0	7.9	12.0	12.9	25.8	40.2	12.9	25.8	40.2	
75	(5.2)	100	(6.9)	2.7	5.4	8.1	2.7	5.4	8.1	8.7	16.0	18.0	8.7	16.0	18.0	
		125	(8.6)	3.8	7.6	11.4	3.8	7.6	11.4	12.2	22.6	25.5	12.2	22.6	25.5	
		150	(10.3)	4.7	9.3	13.9	4.7	9.3	13.9	15.0	27.7	31.2	15.0	27.7	31.2	
		175	(12.1)	5.4	10.7	16.1	5.4	10.7	16.1	17.3	32.0	36.0	17.3	32.0	36.0	
		200	(13.8)	6.0	12.0	18.0	6.0	12.0	18.0	19.3	35.8	40.2	19.3	35.8	40.2	
100	(6.9)	125	(8.6)	1.8	3.6	5.3	1.8	3.6	5.3	5.2	10.3	18.0	5.2	10.3	18.0	
		150	(10.3)	2.5	5.0	7.5	2.5	5.0	7.5	7.3	14.6	25.5	7.3	14.6	25.5	
		175	(12.1)	3.0	6.1	9.2	3.0	6.1	9.2	8.9	17.8	31.2	8.9	17.8	31.2	
		200	(13.8)	3.5	7.1	10.6	3.5	7.1	10.6	10.3	20.6	36.0	10.3	20.6	36.0	
		250	(17.2)	4.3	8.7	13.0	4.3	8.7	13.0	12.6	25.2	44.1	12.6	25.2	44.1	
150	(10.3)	300	(20.7)	HI DP	HI DP	HI DP	HI DP	HI DP	HI DP	HI DP	HI DP	HI DP	HI DP	HI DP	HI DP	
		175	(12.1)	2.7	5.3	8.0	2.7	5.3	8.0	7.7	15.5	18.0	7.7	15.5	18.0	
		200	(13.8)	3.7	7.5	11.2	3.7	7.5	11.2	10.9	21.8	25.5	10.9	21.8	25.5	
		250	(17.2)	5.3	10.6	15.9	5.3	10.6	15.9	15.4	30.9	36.0	15.4	30.9	36.0	
		300	(20.7)	6.5	13.0	19.5	6.5	13.0	19.5	18.9	37.8	44.1	18.9	37.8	44.1	
175	(12.1)	350	(24.1)	HI DP	HI DP	HI DP	HI DP	HI DP	HI DP	HI DP	HI DP	HI DP	HI DP	HI DP	HI DP	
		200	(13.8)	2.7	5.3	8.0	2.7	5.3	8.0	6.9	13.7	18.0	6.9	13.7	18.0	
		250	(17.2)	4.6	9.2	13.8	4.6	9.2	13.8	11.9	23.7	31.2	11.9	23.7	31.2	
		300	(20.7)	5.9	11.9	17.8	5.9	11.9	17.8	15.3	30.6	40.2	15.3	30.6	40.2	
		350	(24.1)	HI DP	HI DP	HI DP	HI DP	HI DP	HI DP	HI DP	HI DP	HI DP	HI DP	HI DP	HI DP	HI DP
200	(13.8)	250	(17.2)	4.3	8.6	12.7	4.3	8.6	12.7	11.0	22.1	25.5	11.0	22.1	25.5	
		300	(20.7)	6.1	12.1	18.0	6.1	12.1	18.0	15.6	31.3	36.0	15.6	31.3	36.0	
		350	(24.1)	7.5	14.8	22.0	7.5	14.8	22.0	19.1	38.3	44.1	19.1	38.3	44.1	
		400	(27.6)	HI DP	HI DP	HI DP	HI DP	HI DP	HI DP	HI DP	HI DP	HI DP	HI DP	HI DP	HI DP	HI DP
		250	(17.2)	3.4	6.9	9.0	3.4	6.9	9.0	8.8	17.5	18.0	8.8	17.5	18.0	
225	(15.5)	300	(20.7)	5.9	11.9	15.6	5.9	11.9	15.6	15.2	30.3	31.2	15.2	30.3	31.2	
		350	(24.1)	7.6	15.3	20.1	7.6	15.3	20.1	19.7	39.1	40.2	19.7	39.1	40.2	
		400	(27.6)	HI DP	HI DP	HI DP	HI DP	HI DP	HI DP	HI DP	HI DP	HI DP	HI DP	HI DP	HI DP	HI DP
		300	(20.7)	5.4	10.7	12.7	5.4	10.7	12.7	13.8	25.5	25.5	13.8	25.5	25.5	
		350	(24.1)	7.6	15.2	18.0	7.6	15.2	18.0	19.5	36.0	36.0	19.5	36.0	36.0	
250	(17.2)	400	(27.6)	9.3	18.6	22.0	9.3	18.6	22.0	23.9	44.1	44.1	23.9	44.1	44.1	

Where "HI DP" is indicated, the actual pressure drop has exceeded the recommended limits of Table 2.
Metric Conversion Factor: GPM X 3.785 = LPM

TABLE 9
AIR CAPACITY - SCFH
S.G. = 1.0 T - 60°F F_L - 0.95
Composition Diaphragm Only

P2 Outlet Pressure psig (Barg)		P1 Inlet Pressure psig (Barg)		3/8" (DN10) Body Size DROOP			1/2" (DN15) Body Size DROOP			3/4" (DN20) Body Size DROOP			1" (DN25) Body Size DROOP		
psig	(Barg)	psig	(Barg)	10%	20%	30%	10%	20%	30%	10%	20%	30%	10%	20%	30%
5	(3.4)	25	(1.7)	200	400	600	200	400	600	400	800	1300	400	800	1300
		50	(3.4)	300	600	1000	300	600	1000	700	1400	2100	700	1400	2100
		75	(5.2)	500	900	1300	500	900	1300	1000	1900	2900	1000	1900	2900
		100	(6.9)	600	1100	1700	600	1100	1700	1200	2400	3700	1200	2400	3700
		125	(8.6)	700	1400	2100	700	1400	2100	1500	3000	4500	1500	3000	4500
		150	(10.3)	800	1600	2500	800	1600	2500	1800	3500	5300	1800	3500	5300
		175	(12.1)	1000	1900	2800	1000	1900	2800	2100	4100	6100	2100	4100	6100
200	(13.8)	1100	2100	3200	1100	2100	3200	2300	4600	6900	2300	4600	6900		
250	(17.2)	HI DP	HI DP	HI DP	HI DP	HI DP	HI DP	HI DP	HI DP	HI DP	HI DP	HI DP	HI DP	HI DP	HI DP
10	(6.9)	25	(1.7)	400	800	1200	400	800	1200	800	1700	2500	800	1700	2500
		50	(3.4)	600	1300	1900	600	1300	1900	1400	2800	4200	1400	2800	4200
		75	(5.2)	900	1800	2700	900	1800	2700	1900	3800	5800	1900	3800	5800
		100	(6.9)	1100	2300	3400	1100	2300	3400	2400	4900	7400	2400	4900	7400
		125	(8.6)	1400	2800	4200	1400	2800	4200	3000	6000	9000	3000	6000	9000
		150	(10.3)	1600	3300	4900	1600	3300	4900	3500	7000	10600	3500	7000	10600
		175	(12.1)	1900	3800	5700	1900	3800	5700	4100	8100	12200	4100	8100	12200
200	(13.8)	2100	4300	6400	2100	4300	6400	4600	9200	13800	4600	9200	13800		
250	(17.2)	2600	5300	7900	2600	5300	7900	5700	11300	17100	5700	11300	17100		
15	(1.0)	25	(1.7)	600	1100	1700	600	1100	1700	1200	2400	3600	1200	2400	3600
		50	(3.4)	1000	1900	2900	1000	1900	2900	2100	4200	6200	2100	4200	6200
		75	(5.2)	1300	2700	4000	1300	2700	4000	2900	5800	8600	2900	5800	8600
		100	(6.9)	1700	3400	5100	1700	3400	5100	3700	7400	11100	3700	7400	11100
		125	(8.6)	2100	4200	6300	2100	4200	6300	4500	9000	13500	4500	9000	13500
		150	(10.3)	2500	4900	7400	2500	4900	7400	5300	10600	15900	5300	10600	15900
		175	(12.1)	2800	5700	8500	2800	5700	8500	6100	12200	18300	6100	12200	18300
200	(13.8)	3200	6400	9700	3200	6400	9700	6900	13800	20800	6900	13800	20800		
250	(17.2)	HI DP	HI DP	HI DP	HI DP	HI DP	HI DP	HI DP	HI DP	HI DP	HI DP	HI DP	HI DP	HI DP	HI DP
20	(1.7)	50	(3.4)	800	1600	2400	800	1600	2400	1800	3600	5400	1800	3600	5400
		75	(5.2)	1100	2300	3500	1100	2300	3500	2500	5100	7700	2500	5100	7700
		100	(6.9)	1500	3000	4400	1500	3000	4400	3300	6500	9800	3300	6500	9800
		125	(8.6)	1800	3600	5400	1800	3600	5400	4000	8000	11900	4000	8000	11900
		150	(10.3)	2100	4300	6400	2100	4300	6400	4700	9400	14100	4700	9400	14100
		175	(12.1)	2400	4900	7300	2400	4900	7300	5400	10800	16200	5400	10800	16200
		200	(13.8)	2700	5500	8300	2700	5500	8300	6100	12300	18400	6100	12300	18400
		250	(17.2)	3400	6800	10200	3400	6800	10200	7500	15100	22600	7500	15100	22600
		300	(20.7)	4000	8100	12200	4000	8100	12200	8900	18000	26900	8900	18000	26900
350	(24.1)	4700	9400	14100	4700	9400	14100	10400	20800	31200	10400	20800	31200		
400	(27.6)	HI DP	HI DP	HI DP	HI DP	HI DP	HI DP	HI DP	HI DP	HI DP	HI DP	HI DP	HI DP	HI DP	HI DP
35	(2.4)	50	(3.4)	1000	2000	3000	1000	2000	3000	2200	4500	6400	2200	4500	6400
		75	(5.2)	1600	3200	4800	1600	3200	4800	3500	7100	10200	3500	7100	10200
		100	(6.9)	2000	4100	6200	2000	4100	6200	4600	9200	13100	4600	9200	13100
		125	(8.6)	2500	5000	7500	2500	5000	7500	5600	11200	16000	5600	11200	16000
		150	(10.3)	2900	5900	8900	2900	5900	8900	6600	13200	18900	6600	13200	18900
		175	(12.1)	3400	6800	10200	3400	6800	10200	7600	15200	21800	7600	15200	21800
		200	(13.8)	3800	7700	11600	3800	7700	11600	8600	17200	24700	8600	17200	24700
		250	(17.2)	4700	9500	14300	4700	9500	14300	10600	21200	30400	10600	21200	30400
		300	(20.7)	5600	11400	17000	5600	11400	17000	12600	25200	36200	12600	25200	36200
350	(24.1)	6500	13200	SONIC	6500	13200	19700	14600	29200	41900	14600	29200	41900		
400	(27.6)	HI DP	HI DP	HI DP	HI DP	HI DP	HI DP	HI DP	HI DP	HI DP	HI DP	HI DP	HI DP	HI DP	HI DP
50	(3.4)	75	(5.2)	900	1800	2700	900	1800	2700	2900	5900	9200	2900	5900	9200
		100	(6.9)	1300	2500	3800	1300	2500	3800	4100	8300	12900	4100	8300	12900
		125	(8.6)	1600	3200	4800	1600	3200	4800	5100	10300	16000	5100	10300	16000
		150	(10.3)	1900	3700	5600	1900	3700	5600	6000	12100	18900	6000	12100	18900
		175	(12.1)	2200	4300	6500	2200	4300	6500	7000	14000	21800	7000	14000	21800
		200	(13.8)	2500	4900	7300	2500	4900	7300	7900	15800	24700	7900	15800	24700
		250	(17.2)	3000	6000	9000	3000	6000	9000	9700	19500	30400	9700	19500	30400
		300	(20.7)	3600	7100	10800	3600	7100	10800	11600	23200	36200	11600	23200	36200
350	(24.1)	4200	8300	12500	4200	8300	12500	13400	26900	41900	13400	26900	41900		
400	(27.6)	4800	9400	14200	4800	9400	14200	15200	30600	47700	15200	30600	47700		

NOTE: Where "HI DP" is indicated, the actual pressure drop has exceeded the recommended limits of Table 2.
Where "SONIC" is indicated, outlet velocity with Schedule 40 pipe exceeds sonic velocity of 1118 fps. Additional flow cannot be obtained, and pipeline velocity is in excess of customary pipe velocity design limits. Flow will be approximately the last indicated value in the column above "SONIC".



Recommend use of Opt-4 Stabilizer.

Metric Conversion Factors: SCFH / 35.31 = Sm³/Hr; SCFH / 37.32 = N-m³/Hr

**TABLE 9 (cont.)
AIR CAPACITY - SCFH
S.G. = 1.0 T - 60°F F_L - 0.95
Composition Diaphragm Only**

P2 Outlet Pressure		P1 Inlet Pressure		3/8" (DN10) Body Size DROOP			1/2" (DN15) Body Size DROOP			3/4" (DN20) Body Size DROOP			1" (DN25) Body Size DROOP		
psig	(Barg)	psig	(Barg)	10%	20%	30%	10%	20%	30%	10%	20%	30%	10%	20%	30%
75	(5.2)	100	(6.9)	1600	3200	4800	1600	3200	4800	5200	9500	10700	5200	9500	10700
		125	(8.6)	2300	4500	6700	2300	4500	6700	7200	13400	15000	7200	13400	15000
		150	(10.3)	2800	5500	8300	2800	5500	8300	8900	16500	18500	8900	16500	18500
		175	(12.1)	3300	6400	9700	3300	6400	9700	10400	19300	21700	10400	19300	21700
		200	(13.8)	3700	7300	11000	3700	7300	11000	11800	21900	24700	11800	21900	24700
		250	(17.2)	4600	9000	13600	4600	9000	13600	14600	27000	30400	14600	27000	30400
		300	(20.7)	5400	10800	16200	5400	10800	16200	17400	32200	36200	17400	32200	36200
		350	(24.1)	6300	12500	18800	6300	12500	18800	20100	37300	41900	20100	37300	41900
100	(6.9)	125	(8.6)	1200	2400	3500	1200	2400	3500	3400	6900	12000	3400	6900	12000
		150	(10.3)	1600	3300	5000	1600	3300	5000	4800	9700	16900	4800	9700	16900
		175	(12.1)	2000	4100	6100	2000	4100	6100	5900	11900	20800	5900	11900	20800
		200	(13.8)	2400	4800	7100	2400	4800	7100	6900	13800	24200	6900	13800	24200
		250	(17.2)	3000	6000	8900	3000	6000	8900	8700	17400	30400	8700	17400	30400
		300	(20.7)	3500	7100	10700	3500	7100	10700	10400	20700	36200	10400	20700	36200
		350	(24.1)	4100	8300	12300	4100	8300	12300	12000	24000	41900	12000	24000	41900
		400	(27.6)	4600	9400	14000	4600	9400	14000	13600	27300	47700	13600	27300	47700
150	(10.3)	175	(12.1)	2100	4200	6300	2100	4200	6300	6100	12300	14300	6100	12300	14300
		200	(13.8)	3000	5900	8900	3000	5900	8900	8600	17300	20100	8600	17300	20100
		250	(17.2)	4200	8400	12600	4200	8400	12600	12200	24500	28600	12200	24500	28600
		300	(20.7)	5200	10400	15700	5200	10400	15700	15200	30500	35500	15200	30500	35500
		350	(24.1)	6100	12300	18400	6100	12300	18400	17900	35800	41700	17900	35800	41700
175	(12.1)	400	(27.6)	7000	14000	21100	7000	14000	21100	20400	40900	47700	20400	40900	47700
		200	(13.8)	2200	4500	6700	2200	4500	6700	5800	11600	15300	5800	11600	15300
		250	(17.2)	3900	7800	11600	3900	7800	11600	10000	20100	26400	10000	20100	26400
		300	(20.7)	5000	10100	15100	5000	10100	15100	13000	26100	34300	13000	26100	34300
		350	(24.1)	6100	12100	18200	6100	12100	18200	15600	31300	41100	15600	31300	41100
200	(13.8)	400	(27.6)	7000	14000	20900	7000	14000	20900	18000	36100	47400	18000	36100	47400
		250	(17.2)	3900	7700	11400	3900	7700	11400	9900	19900	22800	9900	19900	22800
		300	(20.7)	5500	10900	16200	5500	10900	16200	14000	28100	32400	14000	28100	32400
		350	(24.1)	6800	13400	20000	6800	13400	20000	17300	34800	40000	17300	34800	40000
225	(15.5)	400	(27.6)	7900	15700	23400	7900	15700	23400	20300	40700	46800	20300	40700	46800
		250	(17.2)	3200	6500	8500	3200	6500	8500	8400	16600	17100	8400	16600	17100
		300	(20.7)	5600	11200	14800	5600	11200	14800	14400	28700	29500	14400	28700	29500
		350	(24.1)	7200	14600	19100	7200	14600	19100	18700	37200	38200	18700	37200	38200
250 (17.2)	(15.5)	400	(27.6)	8600	17400	22800	8600	17400	22800	22300	44400	45700	22300	44400	45700
		300	(20.7)	5300	10700	12600	5300	10700	12600	13700	25300	25300	13700	25300	25300
		350	(24.1)	7600	15100	17900	7600	15100	17900	19400	35800	35800	19400	35800	35800
400	(27.6)	9300	18600	22000	9300	18600	22000	23900	44100	44100	23900	44100	44100		

NOTE: Recommend use of Opt-4 Stabilizer.

Metric Conversion Factors: SCFH / 35.31 = Sm³/Hr; SCFH / 37.32 = N-m³/Hr

TABLE 10
STEAM - LBS/HR
S.G. = Actual T = Saturated $F_L = 0.95$
Metal Diaphragm Only

P2 Outlet Pressure		P1 Inlet Pressure psig (Barg)		3/8" (DN10) Body Size DROOP			1/2" (DN15) Body Size DROOP			3/4" (DN20) Body Size DROOP			1" (DN25) Body Size DROOP			
psig	(Barg)	psig	(Barg)	10%	20%	30%	10%	20%	30%	10%	20%	30%	10%	20%	30%	
2	(1.4)	25	(1.7)	3	6	10	3	6	10	5	10	14	5	10	14	
		50	(3.4)	5	10	16	5	10	16	8	16	24	8	16	24	
		75	(5.2)	6	14	22	6	14	22	11	22	33	11	22	33	
		100	(6.9)	8	18	28	8	18	28	14	28	42	14	28	42	
		125	(8.6)	10	22	34	10	22	34	17	34	51	17	34	51	
		150	(10.3)	11	26	40	11	26	40	20	40	60	20	40	60	
5	(3.4)	175	(12.1)	HI DP	HI DP	HI DP	HI DP	HI DP	HI DP	HI DP	HI DP	HI DP	HI DP	HI DP	HI DP	
		25	(1.7)	7	15	23	7	15	23	12	23	35	12	23	35	
		50	(3.4)	12	24	38	12	24	38	20	39	59	20	39	59	
		75	(5.2)	17	35	54	17	35	54	28	55	83	28	55	83	
		100	(6.9)	22	44	68	22	44	68	36	70	106	36	70	106	
		125	(8.6)	27	53	82	27	53	82	44	85	128	44	85	128	
10	(6.9)	150	(10.3)	31	63	97	31	63	97	51	100	151	51	100	151	
		175	(12.1)	HI DP	HI DP	HI DP	HI DP	HI DP	HI DP	HI DP	HI DP	HI DP	HI DP	HI DP	HI DP	HI DP
		25	(1.7)	14	28	42	14	28	42	22	44	65	22	44	65	
		50	(3.4)	24	49	74	24	49	74	38	77	115	38	77	115	
		75	(5.2)	34	69	103	34	69	103	54	108	161	54	108	161	
		100	(6.9)	44	90	134	44	90	134	70	140	210	70	140	210	
15	(1.0)	125	(8.6)	53	109	162	53	109	162	85	170	254	85	170	254	
		150	(10.3)	63	128	190	63	128	190	100	199	299	100	199	299	
		175	(12.1)	HI DP	HI DP	HI DP	HI DP	HI DP	HI DP	HI DP	HI DP	HI DP	HI DP	HI DP	HI DP	HI DP
		25	(1.7)	19	37	55	19	37	55	29	57	86	29	57	86	
		50	(3.4)	37	72	109	37	72	109	57	113	171	57	113	171	
		75	(5.2)	52	102	153	52	102	153	80	159	239	80	159	239	
25	(1.7)	100	(6.9)	67	133	200	67	133	200	105	208	312	105	208	312	
		125	(8.6)	82	162	245	82	162	245	128	254	383	128	254	383	
		150	(10.3)	97	190	287	97	190	287	151	299	449	151	299	449	
		175	(12.1)	HI DP	HI DP	HI DP	HI DP	HI DP	HI DP	HI DP	HI DP	HI DP	HI DP	HI DP	HI DP	HI DP
		25	(1.7)	28	57	85	28	57	85	44	88	132	44	88	132	
		50	(3.4)	42	85	127	42	85	127	66	131	197	66	131	197	
35	(2.4)	75	(5.2)	54	110	164	54	110	164	85	169	254	85	169	254	
		100	(6.9)	66	134	200	66	134	200	104	207	311	104	207	311	
		125	(8.6)	80	162	242	80	162	242	125	250	375	125	250	375	
		150	(10.3)	91	186	278	91	186	278	144	287	431	144	287	431	
		175	(12.1)	HI DP	HI DP	HI DP	HI DP	HI DP	HI DP	HI DP	HI DP	HI DP	HI DP	HI DP	HI DP	HI DP
		40	(2.8)	57	113	170	57	113	170	89	176	264	89	176	264	
50	(3.4)	65	(4.5)	76	150	226	76	150	226	118	233	351	118	233	351	
		90	(6.2)	93	184	277	93	184	277	144	287	431	144	287	431	
		115	(7.9)	110	216	326	110	216	326	170	337	507	170	337	507	
		140	(9.7)	129	255	383	129	255	383	200	396	596	200	396	596	
		165	(11.4)	HI DP	HI DP	HI DP	HI DP	HI DP	HI DP	HI DP	HI DP	HI DP	HI DP	HI DP	HI DP	HI DP
		75	(5.2)	59	119	176	59	119	176	112	224	338	112	224	338	
75	(5.2)	100	(6.9)	71	141	209	71	141	209	133	267	402	133	267	402	
		125	(8.6)	82	163	242	82	163	242	154	308	465	154	308	465	
		150	(10.3)	92	185	274	92	185	274	174	348	526	174	348	526	
		200	(13.8)	HI DP	HI DP	HI DP	HI DP	HI DP	HI DP	HI DP	HI DP	HI DP	HI DP	HI DP	HI DP	HI DP
		100	(6.9)	120	236	356	120	236	356	227	454	681	227	454	681	
		125	(8.6)	137	271	408	137	271	408	260	520	780	260	520	780	
100	(6.9)	175	(12.1)	HI DP	HI DP	HI DP	HI DP	HI DP	HI DP	HI DP	HI DP	HI DP	HI DP	HI DP	HI DP	
		200	(13.8)	HI DP	HI DP	HI DP	HI DP	HI DP	HI DP	HI DP	HI DP	HI DP	HI DP	HI DP	HI DP	
135	(9.3)	150	(10.3)	120	241	357	120	241	357	232	464	697	232	464	697	
		200	(13.8)	HI DP	HI DP	HI DP	HI DP	HI DP	HI DP	HI DP	HI DP	HI DP	HI DP	HI DP	HI DP	HI DP

NOTE: Where "HI DP" is indicated, the actual pressure drop has exceeded the recommended limits of Table 2.

Metric Conversion Factor: LBS/HR X 0.4536 = KG/HR

DIMENSIONS & WEIGHTS

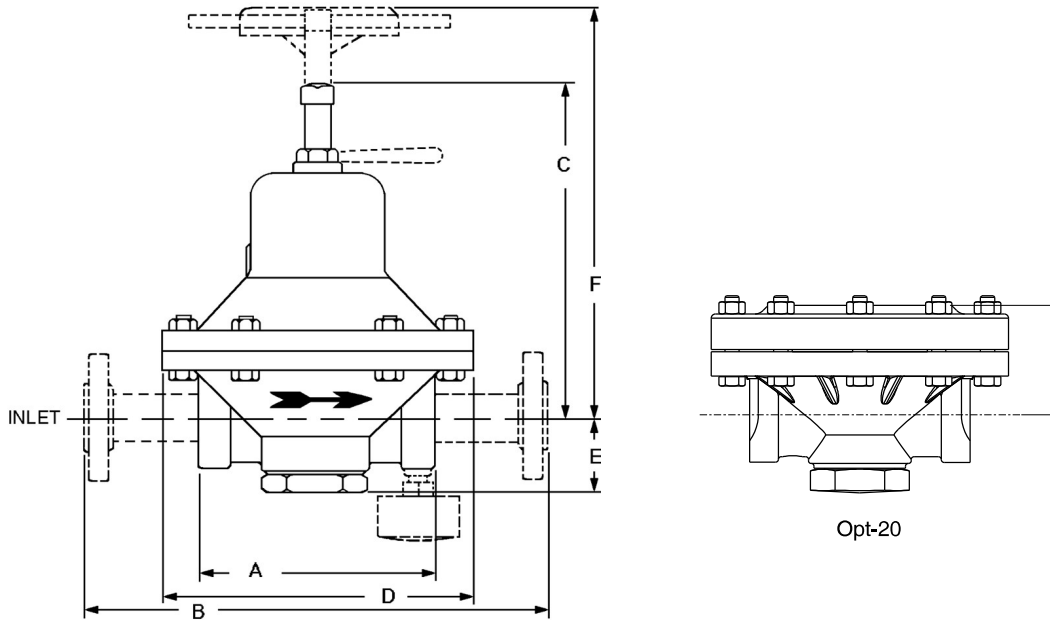

Option No.	Size Inch	Dimensions - English (In.)										Shipping Weight lbs. ⁵
		A	B ¹	B ²	Opt-34 B ¹ or B ²	B ³	C	D	E ⁴	F	G	
Std. & Opt.-20	3/8	3.75*	N/A	N/A	N/A	N/A	6.31	5.31	1.62	7.66	2.18	7
	1/2	3.75	9	9	14	11.75	6.31	5.31	1.62	7.66	2.18	7
	3/4	4.82	11	11.75	14	12.81	7.25	6.50	1.56	8.59	2.40	13
	1	4.82	11	11.75	14	12.81	7.25	6.50	1.56	8.59	2.40	13
-80	3/8	3.75*	N/A	N/A	N/A	N/A	7.30	5.31	1.62	8.60	N/A	10
	1/2	3.75	9	9	14	11.75	7.30	5.31	1.62	8.60	N/A	10
	3/4	4.82	11	11.75	14	12.81	8.50	6.50	1.56	9.90	N/A	21
	1	4.82	11	11.75	14	12.81	8.50	6.50	1.56	9.90	N/A	21

*NPT Only ¹ 150# Flanged, Opt-30 ² 300# Flanged, Opt-30
³ Extended Nipples, Opt-32 ⁴ Add 1 inch for Opt-37. ⁵ Weights do not include angles.

Option No.	Size (DN)	Dimensions - Metric (mm)										Shipping Weight kgs. ⁵
		A	B ¹	B ²	Opt-34 B ¹ or B ²	B ³	C	D	E ⁴	F	G	
Std. & Opt.-20	(10)	95*	N/A	N/A	N/A	N/A	160	135	41	194	55	3.2
	(15)	95	229	229	356	298	160	135	41	194	55	3.2
	(20)	122	279	298	356	325	184	165	40	218	61	5.9
	(25)	122	279	298	356	325	184	165	40	218	61	5.9
-80	(10)	95*	N/A	N/A	N/A	N/A	185	135	41	218	N/A	4.5
	(15)	95	229	229	356	298	185	135	41	218	N/A	4.5
	(20)	122	279	298	356	325	216	165	40	251	N/A	9.5
	(25)	122	279	298	356	325	216	165	40	251	N/A	9.5

*NPT Only ¹ 150# Flanged, Opt-30 ² 300# Flanged, Opt-30
³ Extended Nipples, Opt-32 ⁴ Add 25.4 mm for Opt-37 ⁵ Weights do not include angled options.

The contents of this publication are presented for informational purposes only, and while every effort has been made to ensure their accuracy, they are not to be construed as warranties or guarantees, express or implied, regarding the products or services described herein or their use or applicability. We reserve the right to modify or improve the designs or specifications of such product at any time without notice. Cashco, Inc. does not assume responsibility for the selection, use or maintenance of any product. Responsibility for proper selection, use and maintenance of any Cashco, Inc. product remains solely with the purchaser.

Cryogenic OPT-5 or -36 BRZ or SST Body Mat'l OR For LCC Body Mat'l to -50°F(-46°C)

An "X" in POS 12 followed by a 5-digit control number overrides remaining selections.

2C POS 3 — POS 5 POS 6 & 7 **7** — POS 10 POS 11 POS 12 **0** POS 14 POS 15 POS 16 **0C**

POSITION 3 - SIZES		
Size		CODE
in	(DN)	
1/2"	(15)	4
3/4"	(20)	5
1"	(25)	6

POSITION 5 - BODY & SPRING CHAMBER MATERIALS		
Body / Sp. Ch.	Option	CODE
BRZ/BRZ	-5 *	3
BRZ/BRZ	-5+80 *	L
SST/SST	-36 *	A
SST/SST	**	B
CS/CS (LCC)	**	D

* Cleaned per Spec #S-1134 (Opt-55)
 ** Minimum temperature -50° F (-46° C)

POSITION 6 & 7 - TRIM DESIGNATION NUMBERS (See Tables 3, 4a & 4b)			
BRZ Trim (For Brass Body)		SST Trim (For SST & LCC Body)	
Desig.	CODE	Desig.	CODE
B0	B0	S1	S1
B5	B5	S36	36
		S40B *	4B
		S40C *	4C

* NACE Trim use w/ CS or SST Body down to -50° F (-46° C)

POSITION 10 - END CONNECTIONS	
Description	CODE
NPT - Screwed	1
-30 Opt. - 150 LB RF Flgs. (Std. F to F Dimension) *	6
-30 Opt. - 300 LB RF Flgs. (Std. F to F Dimension) *	7
-34 Opt. - 150 LB RF Flgs. (14" F to F Dimension) *	V
-34 Opt. - 300 LB RF Flgs. (14" F to F Dimension) *	W

* CS/SST Bodies Only, Nipples & angles of same material as body.

POSITION 11 - RANGE SPRINGS		
SST Range Spring		CODE
psig	(Barg)	
2-15	(.14-1.0)	A
10-40	(.69-2.8)	B
30-80	(2.1-5.5)	C
70-150	(4.8-10.3)	D
100-250 *	(6.9-17.2)	P

* Opt-80 only

POSITION 12 - TRIM OPTIONS		
Description	Option	CODE
No Option	---	0
Stabilizer	-4	4
For Special Construction Contact Cashco for Special Product Code.	SPQ	X

POSITION 14 - SPRING CHAMBER OPTIONS		
Description	Option	CODE
No Option	---	0
SST Rain-proof Bug Vent (includes Opt-25). *	-25S	H

* Not Available for Opt-5 or Opt-36

POSITION 15 - BODY OPTIONS		
Description	Option	CODE
No Option	---	0
1/8" (DN6) NPT Tap: for output gauge connection.	-85	T

POSITION 16 - CERTIFICATE OPTIONS		
Description	Option	CODE
No Option	---	0
NACE Const: CS/CS/XX Per MR0175, S40B, S40C Trims.	-40	J
NACE Const: SST/SST/XX Per MR0175, S40B, S40C Trims. Not Available for Opt-36	-40SST	K

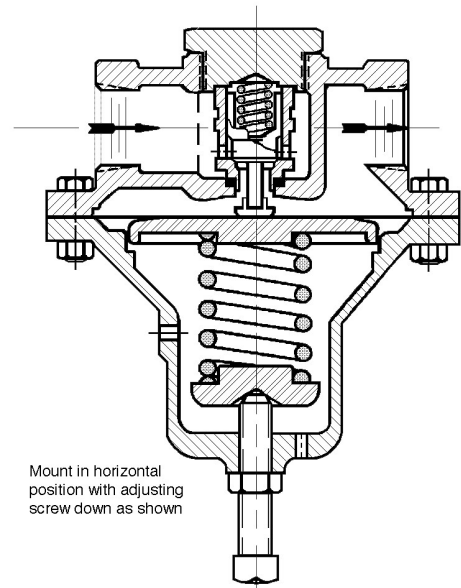

Figure 3: Option -5 and -36 Cryogenic Construction.

Pharmaceutical and Food Industry - OPT-37 or -37S

2K POS 3 — **A** POS 6 & 7 **7** — **1** POS 11 **0 0 0 0 0 0 0 C**

POSITION 3 - SIZES		
Size		CODE
in	(DN)	
1/2"	(15)	4
3/4"	(20)	5
1"	(25)	6

POSITION 6 & 7 - TRIM DESIGNATION NUMBERS (See Tables 3, 4a & 4b)		
STAINLESS STEEL Trim		
Desig.	OPT.-	CODE
S1	37S	S1
S6 *	37	S6

* Not For Steam Service (See Opt-37S)

POSITION 11 - RANGE SPRINGS		
SST Range Spring		CODE
psig	(Barg)	
2-15	(.14-1.0)	A
10-40	(.69-2.8)	B
30-80	(2.1-5.5)	C

OPT -20 PRESSURE LOADED

An "X" in POS 12 followed by a 5-digit control number overrides remaining selections.



POSITION 3 - SIZES		
Size		CODE
in	(DN)	
3/8"	(10)	3
1/2"	(15)	4
3/4"	(20)	5
1"	(25)	6

POSITION 5 - BODY & LOADING CHAMBER MATERIALS	
Material	CODE
CI/BR	6
CI/CS	C
BRZ/BRZ	3
CS/CS (WCB)	5
SST/CS	9

POSITION 6 & 7 - TRIM DESIGNATION NUMBERS (See Tables 3, 4 a& 4b)					
Brass Trim		Stainless Steel Trim			
		Body Material			
Desig.	CODE	Desig.	BR. CODE	CI CODE	CS or SST CODE
B2	B2	S2N	SN	SN	SN
B3	B3	S3	S3	S3	S3
B4 ^	B4	S4	S4	S4	S4
BB	BB	S4N	SD	SD	SD
BJ ^	BJ	S6	-	S6	S6
BK ^	BK	S7 ^	S7	S7	S7
		SB	SB	SB	SB
		SG	SG	SG	SG
		SJ ^	SJ	SJ	SJ
		SK ^	SK	SK	SK

^ Trim Designation Nos. useable for oxygen service.

POSITION 10 - END CONNECTIONS	
Description	CODE
NPT - Screwed	1
-30 Opt. - 150 LB RF Flgs. (Std. F to F Dimension) *	6
-30 Opt. - 300 LB RF Flgs. (Std. F to F Dimension) *	7
-31 Opt. - BSPT - Screwed Tapered Pipe Thread	B
-31P Opt. - BSPP - Screwed Parallel Pipe Thread	P
-32 Opt. - SCH. 80 PE Ext. Nipples *	E
-34 Opt. - 150 LB RF Flgs. (14" F to F Dimension) *	V
-34 Opt. - 300 LB RF Flgs. (14" F to F Dimension) *	W

* CS/SST Bodies-1/2", 3/4", & 1" Sizes Only, Nipples & angles of same material as body.

*** For information on ATEX see pages 8 & 9 on the IOM.**

POSITION 12 - TRIM OPTIONS		
Description	Option	CODE
No Option	---	0
Stabilizer.	-4	4
For Special Construction Contact Cashco for Special Product Code.	SPQ	X

POSITION 15 - BODY OPTIONS		
Description	Option	CODE
No Option	---	0
1/8" (DN6) NPT Tap: for output gauge connection.	-85	T

POSITION 16 - CERTIFICATE OPTIONS		
Description	Option	CODE
No Option	---	0
Special Cleaning: Per Cashco Spec #S-1134. W/ properly selected mat'ls. Suitable for Oxygen Service. BRZ or SST body material.	-55	M
Special Cleaning: Per Cashco Spec #S-1542. All body/spring chamber materials.	-56	N

MODEL D PRODUCT CODER 02/07/20

An "X" in POS 12 followed by a 5-digit control number overrides remaining selections.

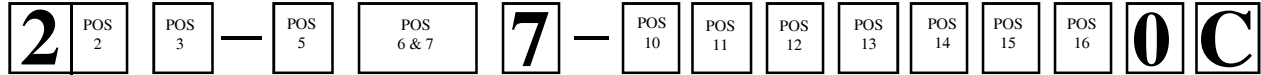

POSITION 2 - GASKETS * & SERVICE		
Gaskets - Service	Options	CODE
Standard : Graphite/NBR - Non-Oxygen	--	B
TFE - Primarily for Oxygen	-45	D
* Refer to Tech Bulletin for temperature limits		

POSITION 3 - SIZES		
Size		CODE
in	(DN)	
3/8"	(10)	3
1/2"	(15)	4
3/4"	(20)	5
1"	(25)	6

POSITION 5 - BODY & SPRING CHAMBER MATERIALS		
Opt.	Body/ Sp. Ch.	CODE
Std.	CI/CI	1
	BRZ/CI	2
	BRZ/BRZ	3
	CS/CI	4
	CS/CS (WCB)	5
	SST/CI	7
	SST/CS	9
	SST/SST	A
-80	BRZ/BRZ	L

NOTE: See TB pg. 5 Table 1 for Design Pressure / Temperature Ratings.

POSITION 6 & 7 - TRIM DESIGNATION NUMBERS (See Tables 3, 4a & 4b)							
Brass Trim		Stainless Steel Trim				Monel Trim	
		Body Material					
Desig.	CODE	Desig.	BR CODE	CI CODE	CS or SST CODE	Desig.	CODE
B0 ‡	B0	S0 ‡	--	S0	S0	M1 %	M1
B1 ‡	B1	S1 ^ ‡	S1	S1	S1	M36 %	M6
B2	B2	S2 ‡	S2	S2	S2		
B3	B3	S2N	SN	SN	SN		
B4 ^	B4	S3	S3	S3	S3		
B5 ^ ‡	B5	S4	S4	S4	S4		
BB	BB	S4N	SD	SD	SD		
BJ ^	BJ	S6	--	S6	S6		
BK ^	BK	S7 ^	S7	S7	S7		
		S9 ‡	--	S9	S9		
		SK ^	SK	SK	SK		
		S36 ^ ‡	36	36	36		
		S40	40	40	40		
		S40C	--	--	4C		
		S40T	--	--	4T		
		S40V	--	--	4V		
		SB	SB	SB	SB		
		SG	SG	SG	SG		
		SJ ^	SJ	SJ	SJ		

^ Trim Designation Nos. usable for oxygen service.
 ‡ Trim Designation Nos. usable with Opt-80 spring range.
 % For O₂ service above 290 psid.

POSITION 10 - END CONNECTIONS	
Description	CODE
NPT - Screwed	1
-30 Opt. - 150 LB RF Flgs. (Std. F to F Dimension) *	6
-30 Opt. - 300 LB RF Flgs. (Std. F to F Dimension) *	7
-31 Opt. - BSPT - Screwed Tapered Pipe Thread	B
-31P Opt. - BSPP - Screwed Parallel Pipe Thread	P
-32 Opt. - SCH. 80 PE Ext. Nipples *	E
-34 Opt. - 150 LB RF Flgs. (14" F to F Dimension) *	V
-34 Opt. - 300 LB RF Flgs. (14" F to F Dimension) *	W

* CS/SST Bodies-1/2", 3/4", & 1" Sizes Only, Nipples & ranges of same material as body.

POSITION 11 - RANGE SPRINGS		
Steel Range Spring		CODE
psig	(Barg)	
2-15	(.14-1.0)	1
10-40	(.69-2.8)	2
30-80	(2.1-5.5)	3
70-150	(4.8-10.3)	4
100-250 (6.9-17.2)		P
Opt. -80 only		

POSITION 12 - TRIM OPTIONS			
Description	Option	CODE	
No Option	---	0	
Stabilizer	-4	4	
For Special Construction Contact Cashco for Special Product Code	SPQ	X	

POSITION 13 - FEATURE OPTIONS			
Description	Option	CODE	
No Option	---	0	
Handwheel & Locking Lever.	-3	3	

POSITION 14 - SPRING CHAMBER OPTIONS		
Description	Option	CODE
No Option	---	0
1/8" (DN6) NPT Vent Tap for CI, CS, SST mat'ls. (Is Standard with Brass Spring Chamber)	-25	D
Plastic Rain-proof Bug Vent (includes Opt-25).	-25P	P
SST Rain-proof Bug Vent (includes Opt-25).	-25S	H

POSITION 15 - BODY OPTIONS		
Description	Op-tion	CODE
No Option	---	0
1/8" (DN6) NPT Tap on output for gauge connection.	-85	T
1/8" (DN6) NPT Taps -one at inlet, one at outlet, for Opt-34	-87	V

POSITION 16 - CERTIFICATE OPTIONS		
Description	Option	CODE
No Option	---	0
NACE Const: CS/CS/XX Per MR0175, S40, S40T, S40V Trims.	-40	J
NACE Const: SST/SST/XX Per MR0175, S40, S40T, S40V Trims.	-40SST	K
Special Cleaning: Per Cashco Spec #S-1134. W/ properly selected mat'ls. Suitable for Oxygen Service. BRZ or SST body material.	-55	M
Special Cleaning: Per Cashco Spec #S-1542.	-56	N

*** For information on ATEX see pages 8 & 9 on the IOM.**