

B

Model
T6000



The T6000 Series is designed for precision applications providing maximum versatility. The modular construction permits any basic unit to be used in the explosion-proof, rack, wall, pipe, panel, DIN rail or 3, 5, 10, or 15 unit manifold configurations. Servicing or calibration is quick and easy.

Features

- Field reversible feature provides output which is directly or inversely proportional to the input signal.
- RFI/EMI Protection eliminates susceptibility to electromagnetic and radio interference.
- Six output pressure ranges meet final control element requirements.
- Six input signal ranges meet most process and machine requirements.
- Compact size permits use in space restricted areas.
- Explosion-Proof NEMA 4X, IP65, Type 4 Enclosure available for outdoor and indoor installations.
- Input and Output ports on both front and bottom simplifies pneumatic piping.

Operating Principles

Standard Range

The T6000 Series is an electro-pneumatic device that converts a DC input signal to a pneumatic output. This device is made up of two sections, the Primary Converting Section and the Pneumatic Relay Section. The Coil and Suspension Spring, in the Primary Converting Section, is used as a Flapper. Together the Flapper and Nozzle work to control the signal pressure. The signal pressure acts on the Upper Control Diaphragm, in the Pneumatic Relay Section, which sets the output pressure. The output pressure is sensed by the Lower Control Diaphragm, in the Pneumatic Relay Section, which maintains the output pressure.

Extended Range

The Extended Unit is made up of three sections, the Primary Control Section, the Pneumatic Relay Section, and an additional Pneumatic Relay Section. The additional Relay Section is used to amplify the output pressure.

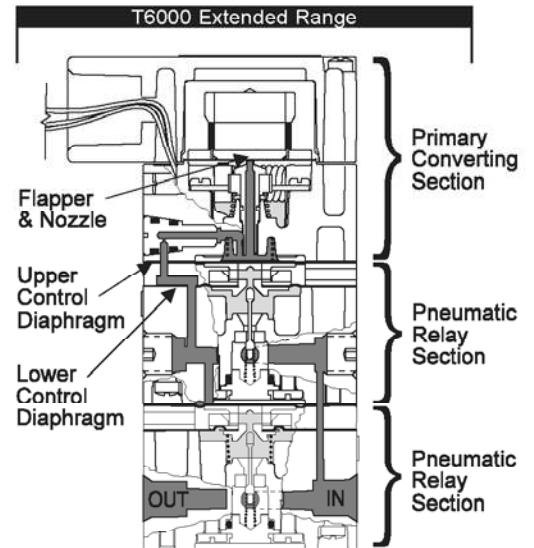
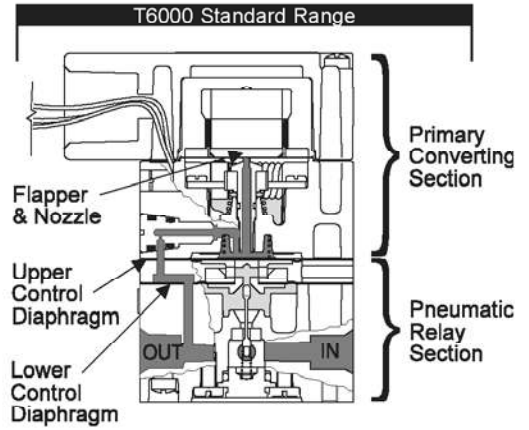

Model T6000 Electro-Pneumatic I/P, E/P Transducer

B

Model T6000

TA6000 Extended Range

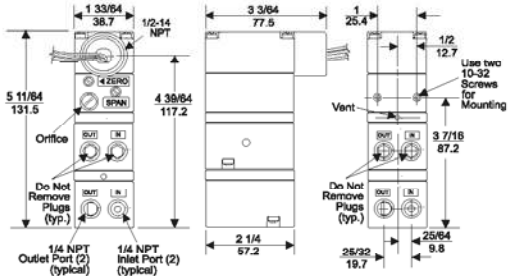

TT6000 Extended Range

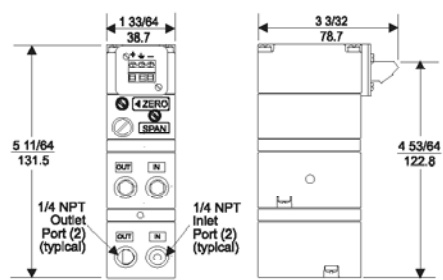

TD6000 Extended Range

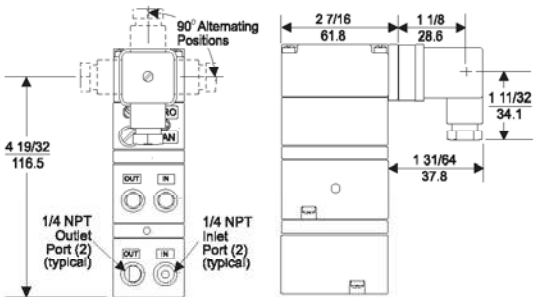

TR6000 Extended Range

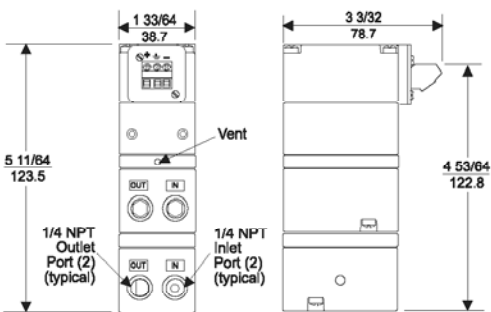

TJ6000 Extended Range

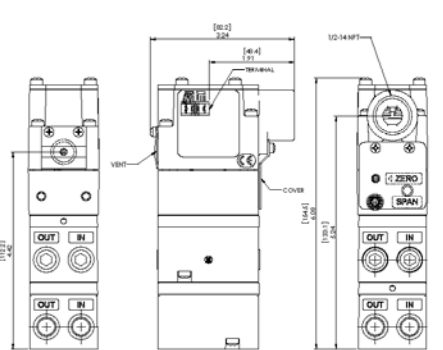

Specifications:
T6000 Extended Range Transducers

Output Range	psig [BAR] (kPa)	0-30 [0-2.0] (0-200)	0-60 [0-4.0] (0-400)	0-120 [0-8.0] (0-800)
Supply Pressure ¹	psig [BAR] (kPa)	35-150 [2.5-10.0] (250-1000)	65-150 [4.6-10.0] (460-1000)	125-150 [8.8-10.0] (880-1000)
Minimum Span	psig [BAR] (kPa)	12 [0.8] (80)	25 [1.5] (150)	50 [3.5] (350)
Impedance (OHMS) / Input Signal	4-20 mA / 10-50 mA / 0-5 VDC / 0-10 VDC / 1-5 VDC	250 / 100 / 439 / 878 / 400	256 / 103 / 469 / 938 / 453	270 / 108 / 446 / 893 / 430
Air Consumption (per ISA S51.1) SCFH		12.0 (.34 m ³ /HR)	13.0 (.36 m ³ /HR)	17.0 (.48 m ³ /HR)
Independent Linearity (per ISA S51.1)		±0.75% FS	±1.0% FS	±1.0% FS
Hysteresis & Repeatability (per ISA S51.1)		<1.0% FS @ 35 psig, [2.5 BAR], (250 kPa)	<1.0% FS @ 65 psig, [4.6 BAR], (460 kPa)	<1.0% FS @ 125 psig, [8.8 BAR], (880 kPa)
Supply Pressure Effect on Output [BAR] (kPa) For a 25 psig, [1.7 BAR], (170 kPa) supply change	psig [BAR] (kPa)	0.5 [0.03] (4.0)	1.0 [0.07] (7.0)	1.5 [0.1] (10.5)

Flow Rate (SCFM)
11 (18.7 m³/HR) @ 150 psig, [10 BAR, (1000 kPa) Supply & 9 psig, [0.6 BAR], (60 kPa) Output.

RFI / EMI Effect
Less than 0.5% of Span @ 30 V/m class 3 Band ABC (20-1000 mHz) per SAMA PMC 33.1 1978 and less than 0.5% of Span @ 10 V/m level 3, 27-500 mHz Band per IEC Standard 801-3 1984. EMC Directive 89/336/EEC European Norms EN 50081-2 and EN 50082-2.





Temperature Range (per ISA S51.1)
-20 °F to +150°F, (-30°C to +65°C)

Materials of Construction
Body and Housing Aluminum
Orifice Nickel Plated Brass
Trim Zinc Plated Steel
Diaphragm Nitrile

¹ Supply Pressure must be no less than 5 psig, [0.35 BAR], (35 kPa) above maximum output.

NOTE: Model TR6000 Transducer is designed for use with the TR Rack Kit. Physically, it is the same as the TT6000 Unit except that the terminal block has been rotated to the rear.

Hazardous Area Specifications

	Explosion-Proof	Intrinsically Safe														
<p>Factory Mutual (FM) Approvals</p> 	<p>Class I, Division 1, Groups B, C and D; Class II, Division 1, Groups E, F, and G; NEMA 4X Enclosure.</p>	<p>Class I, II, and III, Division 1, Groups A, B, C, D, E, F, and G.</p> <table border="1" style="width: 100%; border-collapse: collapse;"> <thead> <tr> <th colspan="2" style="text-align: left; padding: 2px;"><i>Entity Parameters</i></th> </tr> </thead> <tbody> <tr> <td style="padding: 2px;">$V_{max}^1 = 40 \text{ VDC}$</td> <td style="padding: 2px;">$C_i^3 = 0 \mu\text{F}$</td> </tr> <tr> <td style="padding: 2px;">$I_{max}^2 = 125 \text{ mA}$</td> <td style="padding: 2px;">$L_i^4 = 3 \text{ mH}$</td> </tr> <tr> <td style="padding: 2px;"><small>¹V_{max} = Max. Voltage</small></td> <td style="padding: 2px;"><small>³C_i = Capacitance</small></td> </tr> <tr> <td style="padding: 2px;"><small>²I_{max} = Max. Current</small></td> <td style="padding: 2px;"><small>⁴L_i = Inductance</small></td> </tr> </tbody> </table>	<i>Entity Parameters</i>		$V_{max}^1 = 40 \text{ VDC}$	$C_i^3 = 0 \mu\text{F}$	$I_{max}^2 = 125 \text{ mA}$	$L_i^4 = 3 \text{ mH}$	<small>¹V_{max} = Max. Voltage</small>	<small>³C_i = Capacitance</small>	<small>²I_{max} = Max. Current</small>	<small>⁴L_i = Inductance</small>				
<i>Entity Parameters</i>																
$V_{max}^1 = 40 \text{ VDC}$	$C_i^3 = 0 \mu\text{F}$															
$I_{max}^2 = 125 \text{ mA}$	$L_i^4 = 3 \text{ mH}$															
<small>¹V_{max} = Max. Voltage</small>	<small>³C_i = Capacitance</small>															
<small>²I_{max} = Max. Current</small>	<small>⁴L_i = Inductance</small>															
<p>Canadian Standards Association (CSA) Approvals</p> 	<p>Class I, Division 1, Groups B, C and D; Class II, Division 1, Groups E, F, and G; Type 4 Enclosure.</p>	<p>Class I, Division 1, Groups A, B, C and D; Temperature Code T3C. Rated 4-20 mA, 30 VDC Maximum.</p> <div style="border: 1px solid black; padding: 5px; margin-top: 10px;"> <p>Approvals are valid when connected through a Shunt Zener Diode Safety Barrier meeting the following parametric requirements:</p> <p>System Type 1: Single Channel Polarized Rated: 28V Max. 300 Ohm Min.</p> <p>System Type 2: Dual Channel Polarized Rated: 28V Max. 300 Ohm Min.</p> <p>System Type 3: a. 28V Max. 300 Ohm Min. & 10V Max. 50 Ohm Min. return. b. 28.5V Max. 300 Ohm Min. & 9V Max. 50 Ohm Min return.</p> </div>														
<p>ATEX Approvals</p> 		<p> II 1G EEx ia IIC T4 ($T_a = -20^\circ\text{C}$ to $+65^\circ\text{C}$)</p> <table border="1" style="width: 100%; border-collapse: collapse;"> <thead> <tr> <th colspan="2" style="text-align: left; padding: 2px;"><i>Transducer Parameters</i></th> </tr> </thead> <tbody> <tr> <td style="padding: 2px;">$U_{max}^1 = 28 \text{ V}$</td> <td style="padding: 2px;">$P_i^3 = 0.653 \text{ W}$</td> </tr> <tr> <td style="padding: 2px;">$I_{max}^2 = 93 \text{ mA}$</td> <td style="padding: 2px;">$C_i^4 = 0$</td> </tr> <tr> <td style="padding: 2px;"></td> <td style="padding: 2px;">$L_i^5 = 0$</td> </tr> <tr> <td style="padding: 2px;"><small>¹U_{max} = Max. Voltage</small></td> <td style="padding: 2px;"><small>³P_i = Max. Power</small></td> </tr> <tr> <td style="padding: 2px;"><small>²I_{max} = Max. Current</small></td> <td style="padding: 2px;"><small>⁴C_i = Capacitance</small></td> </tr> <tr> <td style="padding: 2px;"></td> <td style="padding: 2px;"><small>⁵L_i = Inductance</small></td> </tr> </tbody> </table>	<i>Transducer Parameters</i>		$U_{max}^1 = 28 \text{ V}$	$P_i^3 = 0.653 \text{ W}$	$I_{max}^2 = 93 \text{ mA}$	$C_i^4 = 0$		$L_i^5 = 0$	<small>¹U_{max} = Max. Voltage</small>	<small>³P_i = Max. Power</small>	<small>²I_{max} = Max. Current</small>	<small>⁴C_i = Capacitance</small>		<small>⁵L_i = Inductance</small>
<i>Transducer Parameters</i>																
$U_{max}^1 = 28 \text{ V}$	$P_i^3 = 0.653 \text{ W}$															
$I_{max}^2 = 93 \text{ mA}$	$C_i^4 = 0$															
	$L_i^5 = 0$															
<small>¹U_{max} = Max. Voltage</small>	<small>³P_i = Max. Power</small>															
<small>²I_{max} = Max. Current</small>	<small>⁴C_i = Capacitance</small>															
	<small>⁵L_i = Inductance</small>															

¹ ATEX not available for Explosion-Proof.

² Intrinsically Safe for Current Inputs Units Only.



B

Model
T6000

Model T6000 Electro-Pneumatic I/P, E/P Transducer

Mounting Kits

B

Model T6000

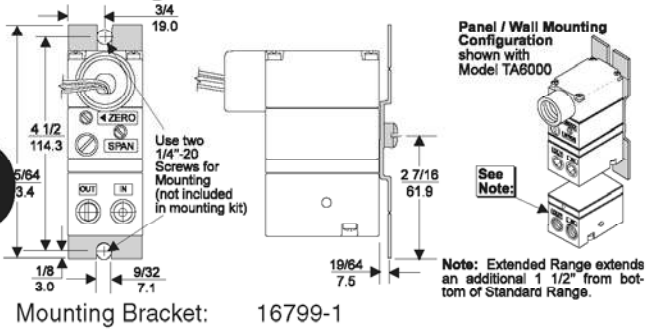

Mounting Bracket: 16799-1

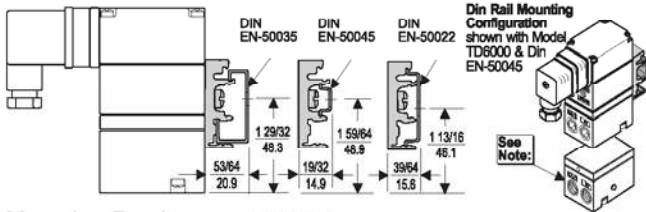

Mounting Bracket: 16893-1

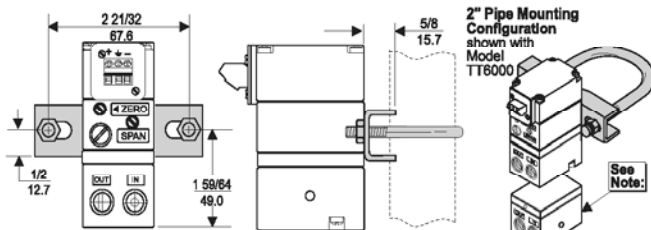

Mounting Bracket: 19254-1

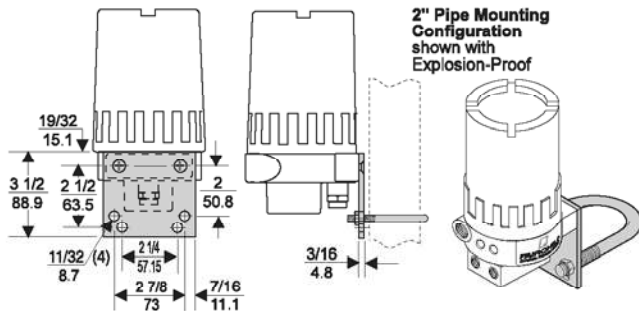

Mounting Bracket: 18187-1

Model T6000 Transducer Kits & Accessories

- Mounting Bracket Kits 16799-1 (included with unit)
- 16893-1 (included with unit)
- 19254-1 (sold separately)
- 18187-1 (sold separately)

Catalog Information

Catalog Number T 6 0 0 0

Electrical Connections

- 1/2 NPT Conduit A
- Fitting with Pigtail D
- DIN43650 Connection J
- Junction Box R
- Rack Mount T
- Terminal Block
- (leave blank if Explosion-Proof)

Underwriting Group

- Canadian Standards C
- ATEX ¹ E
- Factory Mutual F

Approval Class

- Explosion-Proof XPD
- Dust Ignition-Proof (includes NEMA 4X/IP 65)
- Intrinsically Safe² I
- None (leave blank)

Input

- 4-20 mA 4
- 10-50 mA 3
- 1-5 VDC 5
- 0-5 VDC 7
- 1-9 VDC 9
- 0-10 VDC 0

Output (Select appropriate psig, [BAR], or (kPa) range.)

- 3-15 psig 01
- 3-27 psig 02
- 6-30 psig 03
- 0-30 psig 04
- 0-60 psig 05
- 0-120 psig 06
- [0.2-1.0 BAR] 11
- [0.2-1.8 BAR] 12
- [0.4-2.0 BAR] 13
- [0-2.0 BAR] 14
- [0-4.0 BAR] 15
- [0-8.0 BAR] 16
- (20-100 kPa) 21
- (20-180 kPa) 22
- (40-200 kPa) 23
- (0-200 kPa) 24
- (0-400 kPa) 25
- (0-800 kPa) 26

Options

- BSPT Thread³
- IP65 Enclosure U

¹ ATEX not Available for Explosion-Proof.

² Intrinsically Safe for Current Input Units Only.

³ Not Available for CSA Explosion-Proof Units.