



### Features

The Model 10BP is a high capacity regulator that relieves excess pressure in a pneumatic system.

The Model 10BP provides greater accuracy than relief valves over a narrow pressure range. The Model 10BP is an excellent choice for a wide range of precision applications.

The Model 10BP has the following features:

- Control sensitivity of 1/8" water column allows use in precision applications.
- A separate Control Chamber and Aspirator Tube isolate the diaphragm from the main flow to eliminate hunting and buzzing.
- Unit construction lets you service the Model 10BP without removing it from the line.
- Mounting Bracket is available.

### Operating Principles

The Model 10BP Regulator uses the force balance principle to open the Relief Valve and vent system pressure when the set point is exceeded.

Downstream pressure is transmitted through the Aspirator Tube to the bottom of the Diaphragm Assembly. When you adjust the range screw for a specific set point, the Positive Bias Spring compresses and exerts a force on the top of the Diaphragm Assembly. As long as the pressure acting on the bottom of the Diaphragm Assembly produces a force less than the spring force acting on the top of the Diaphragm Assembly, the Relief Valve remains closed. When system pressure increases, the force on the bottom of the Diaphragm Assembly increases until it reaches the set point. When system pressure increases beyond the set point, the assembly moves upward, lifting the Relief Valve from its seat and vents the downstream air.

If downstream pressure decreases below the set point, the assembly moves downward closing the Relief Valve.

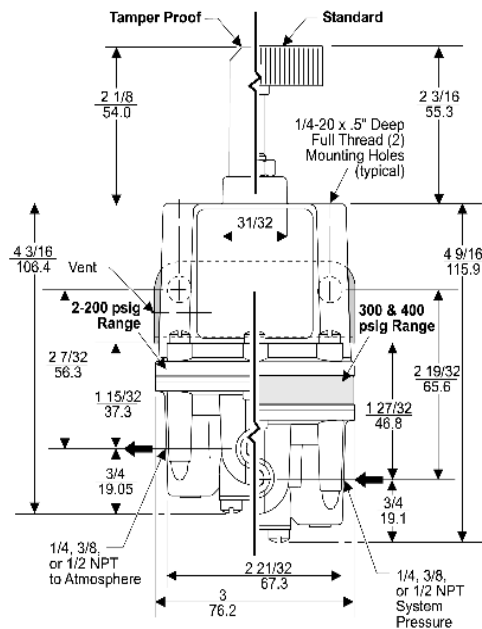
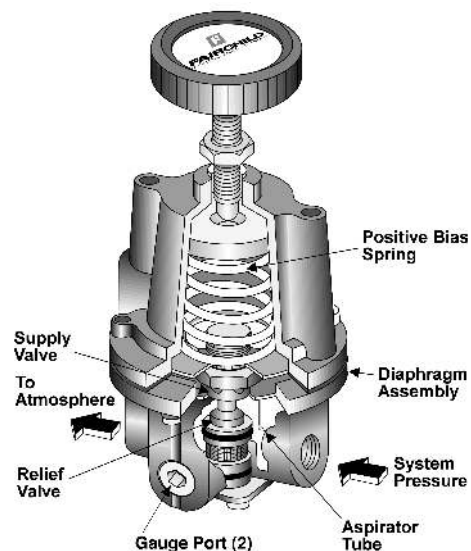

**Technical Information**

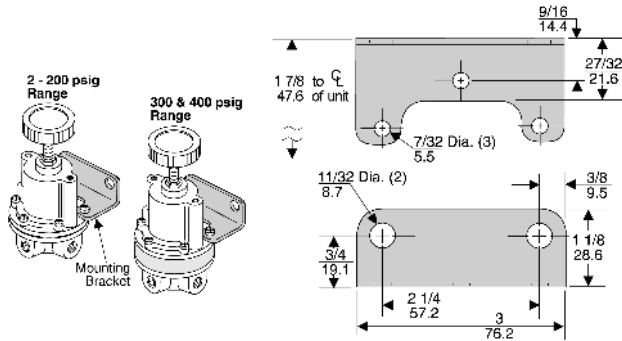
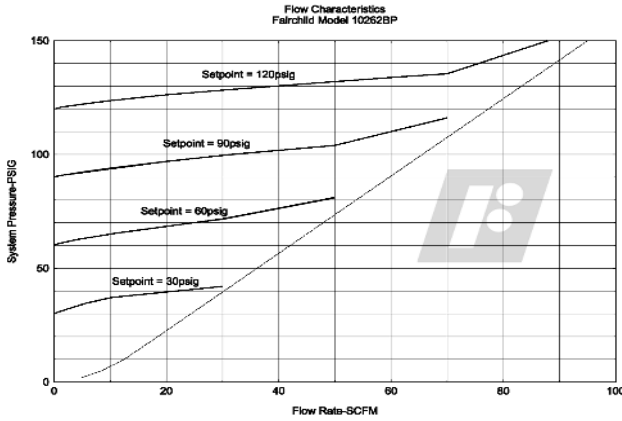

**Model 10BP Regulator Kits & Accessories**

Mounting Bracket Kit .....09921 (Sold separately)

**Specifications**

Set Point Range	System Pressure (Maximum)
2-200 psig [0.15-14 BAR] (15-1400 kPa)	300 psig [21.0 BAR] (2100 kPa)

300-400 psig [21-28 BAR] (2100-2800 kPa)	500 psig [35.0 BAR] (3500 kPa)
--	--------------------------------------

**Flow Capacity (SCFM)**

40 (68 m<sup>3</sup>/HR) @ 100 psig, [7.0 BAR], (700 kPa) system pressure

**Sensitivity**

Less than 1/8" (.32 cm) Water Column

**Ambient Temperature**

-40° F to +200° F, (-40° C to +93° C)

**Materials of Construction**

Body and Housing .....Aluminum  
Trim .....Zinc Plated Steel, Brass  
Nozzle .....Nitrile on Dacron

**Catalog Information**

Catalog Number 1 0 2   BP

**Pressure Range**

psig	[BAR]	(kPa)
0-2	[0-0.15]	(0-15)
0-10	[0-0.7]	(0-70)
0-20	[0-1.5]	(0-150)
.5-30	[0.03-2.0]	(3-200)
1-60	[0.1-4.0]	(10-400)
2-150	[0.15-10.0]	(15-1000)
3-200	[0.2-14.0]	(20-1400)
5-300	[0.35-21.0]	(35-2100)
5-400	[0.35-28.0]	(35-2800)

- 1
- 2
- 0
- 3
- 4
- 6
- 7
- 8
- 9

**Pipe Size**

1/4" NPT	2
3/8" NPT	3
1/2" NPT	4

**Options**

Silicone Elastomers <sup>1</sup>	A
BSPP (Parallel) <sup>2</sup>	H
Fluorocarbon (Viton) Elastomers	J
Screwdriver Adjust	S
Tamper Proof	T
BSPT (Tapered)	U

<sup>1</sup> Maximum System Pressure - 75 psig, [5.0 BAR], (500 kPa)  
<sup>2</sup> BSPP Threads in Inlet & Outlet Ports Only. Others BSPT.

**Installation**

For installation instructions, refer to the *Fairchild Model 10BP Pneumatic Precision Back Pressure Regulator Installation, Operation and Maintenance Instructions, IS-100010BP.*